



Operating Instructions and Parts Manual
12-inch Variable Speed
Vertical Band Saw
Model VBS-1207VS-DC



JET
427 New Sanford Road
LaVergne, Tennessee 37086
Ph.: 800-274-6848
www.jettools.com

Part No. M-JT1-1375
Edition 3 11/2024
Copyright © 2024 JET

1.0 Warranty and Service

JET warrants every product it sells against manufacturers' defects. If one of our tools needs service or repair, please contact Technical Service by calling 1-800-274-6846, 8AM to 5PM CST, Monday through Friday.

Warranty Period

The general warranty lasts for the time period specified in the literature included with your product or on the official JET branded website.

- JET products carry a limited warranty which varies in duration based upon the product. (See chart below)
- Accessories carry a limited warranty of one year from the date of receipt.
- Consumable items are defined as expendable parts or accessories expected to become inoperable within a reasonable amount of use and are covered by a 90 day limited warranty against manufacturer's defects.

Who is Covered

This warranty covers only the initial purchaser of the product from the date of delivery.

What is Covered

This warranty covers any defects in workmanship or materials subject to the limitations stated below. This warranty does not cover failures due directly or indirectly to misuse, abuse, negligence or accidents, normal wear-and-tear, improper repair, alterations or lack of maintenance. JET woodworking machinery is designed to be used with Wood. Use of these machines in the processing of metal, plastics, or other materials outside recommended guidelines may void the warranty. The exceptions are acrylics and other natural items that are made specifically for wood turning.

Warranty Limitations

Woodworking products with a Five Year Warranty that are used for commercial or industrial purposes default to a Two Year Warranty. Please contact Technical Service at 1-800-274-6846 for further clarification.

How to Get Technical Support

Please contact Technical Service by calling 1-800-274-6846. **Please note that you will be asked to provide proof of initial purchase when calling.** If a product requires further inspection, the Technical Service representative will explain and assist with any additional action needed. JET has Authorized Service Centers located throughout the United States. For the name of an Authorized Service Center in your area call 1-800-274-6846 or use the Service Center Locator on the JET website.

More Information

JET is constantly adding new products. For complete, up-to-date product information, check with your local distributor or visit the JET website.

How State Law Applies

This warranty gives you specific legal rights, subject to applicable state law.

Limitations on This Warranty

JET LIMITS ALL IMPLIED WARRANTIES TO THE PERIOD OF THE LIMITED WARRANTY FOR EACH PRODUCT. EXCEPT AS STATED HEREIN, ANY IMPLIED WARRANTIES OF MERCHANTABILITY AND FITNESS FOR A PARTICULAR PURPOSE ARE EXCLUDED. SOME STATES DO NOT ALLOW LIMITATIONS ON HOW LONG AN IMPLIED WARRANTY LASTS, SO THE ABOVE LIMITATION MAY NOT APPLY TO YOU.

JET SHALL IN NO EVENT BE LIABLE FOR DEATH, INJURIES TO PERSONS OR PROPERTY, OR FOR INCIDENTAL, CONTINGENT, SPECIAL, OR CONSEQUENTIAL DAMAGES ARISING FROM THE USE OF OUR PRODUCTS. SOME STATES DO NOT ALLOW THE EXCLUSION OR LIMITATION OF INCIDENTAL OR CONSEQUENTIAL DAMAGES, SO THE ABOVE LIMITATION OR EXCLUSION MAY NOT APPLY TO YOU.

JET sells through distributors only. The specifications listed in JET printed materials and on official JET website are given as general information and are not binding. JET reserves the right to effect at any time, without prior notice, those alterations to parts, fittings, and accessory equipment which they may deem necessary for any reason whatsoever. JET® branded products are not sold in Canada by JPW Industries, Inc.

Product Listing with Warranty Period

90 Days – Parts; Consumable items
1 Year – Motors; Machine Accessories
2 Year – Metalworking Machinery; Electric Hoists, Electric Hoist Accessories; Woodworking Machinery used for industrial or commercial purposes
5 Year – Woodworking Machinery
Limited Lifetime – JET Parallel clamps; VOLT Series Electric Hoists; Manual Hoists; Manual Hoist Accessories; Shop Tools; Warehouse & Dock products; Hand Tools; Air Tools

NOTE: JET is a division of JPW Industries, Inc. References in this document to JET also apply to JPW Industries, Inc., or any of its successors in interest to the JET brand.

2.0 Table of Contents

Section	Page
1.0 Warranty and Service	2
2.0 Table of Contents	3
3.0 Safety Warnings	4
4.0 About This Manual	5
5.0 Specifications	6
6.0 Uncrating and Checking Contents	7
6.1 Contents	7
6.2 Cleaning	7
6.3 Lifting and Transporting	7
7.0 Installation	7
7.1 Anchoring the Machine	8
8.0 Electrical Connections	8
9.0 Product and Controls Identification	9
10.0 Adjustments	12
10.1 Blade Tensioning	12
10.2 Blade Guide Adjustment	13
10.3 Guide Post Adjustment	13
10.4 Changing Saw Blades	14
11.0 Blade Selection	14
11.1 Material Composition	14
11.2 Tooth Shape	14
11.3 Set Type	14
11.4 Blade Terminology	14
11.5 Breaking in a Band Saw Blade	15
11.6 Metal Chip Indicators	15
11.7 Blade Care	15
11.8 Blade Breakage	15
12.0 Band Saw Operation	15
12.1 Before Each Use	15
12.2 While Saw is Running	15
12.3 Blade Break-In Procedure	16
12.4 Evaluating Cutting Efficiency	16
12.5 Material Selection	16
12.6 Basic Operating Procedure	16
13.0 Welder Operation	17
13.1 Preparing the Saw Blade Prior to Welding	17
13.2 Welding	18
13.3 Annealing	19
13.4 Blade Grinding	20
13.5 Secondary Annealing	20
13.6 Welder Clean-Up	20
14.0 Maintenance	21
14.1 Daily Maintenance	21
14.2 Weekly Maintenance	21
14.3 Monthly Maintenance	21
14.4 Lubrication Schedule	21
15.0 Troubleshooting	22
15.1 Driver Error Codes	22
15.2 Operating Problems	23
15.3 Mechanical and Electrical Problems	24
15.4 Welded Blade Inspection	25
15.5 Welder Mechanical Problems	26
16.0 Typical Band Saw Operations	27
17.0 Replacement Parts	27
17.1.1 VBS-1207VS-DC Cabinet Assembly – Exploded View	28
17.1.2 VBS-1207VS-DC Guide Post & Work Table Assembly – Exploded View	29
17.1.3 VBS-1207VS-DC Drive System Assembly – Exploded View	30
17.1.4 VBS-1207VS-DC Welder Assembly – Exploded View	31
17.2.1 VBS-1207VS-DC Band Saw – Parts List	32



3.0 Safety Warnings

1. Read and understand the entire owner's manual before attempting assembly or operation.
2. Read and understand the warnings posted on the machine and in this manual. Failure to comply with all warnings may cause serious injury.
3. Replace the warning labels if they become obscured or removed.
4. This band saw should only be used by properly trained and skilled operators. Do not use until you are trained and familiar with the correct and safe operation of this band saw.
5. Only use this band saw for its intended use. If used for other purposes, JET disclaims any real or implied warranty and holds itself harmless from any injury that may result from that use.
6. Do not modify this machine in any way. Modifications can cause serious injury to the operator or others and may damage the machine.
7. Do not bypass or defeat any safety interlock systems.
8. Always wear approved safety glasses/face shields while using this band saw. Everyday eyeglasses only have impact resistant lenses; they are not safety glasses.
9. Wear ear protectors (plugs or muffs) during extended periods of operation.
10. Wear appropriate dust mask. Dust created while using machinery can cause cancer, birth defects, and long-term respiratory damage. Be aware of the dust hazards associated with all types of materials.
11. Before operating this band saw, remove tie, rings, watches and other jewelry, and roll sleeves up past the elbows. Remove all loose clothing and confine long hair. Non-slip footwear or anti-skid floor strips are recommended. Do not wear gloves when operating the band saw. Always wear leather gloves when handling the blade during maintenance and repair activity.
12. Do not operate this machine while tired or under the influence of drugs, alcohol or any medication.
13. Be aware of cut and pinch points. The moving saw blade will cause serious injury if contacted. Keep fingers, hands, arms, and all body parts away from the moving saw blade.
14. This machine has a laser line cutting guide. Do not stare into beam or view directly with optical instruments. Avoid exposure to the laser beam.
15. Make sure the OFF button is pressed before connecting the machine to the power supply. Turn off all controls before unplugging.
16. Make sure the machine is properly grounded. Connect to a properly grounded outlet only. See Grounding instructions.
17. Make all machine adjustments or maintenance with the machine OFF and unplugged from the power source.
18. Before turning machine ON, remove adjusting keys and wrenches. Form a habit of checking to see that keys and adjusting wrenches are removed from the machine before use.
19. Always keep safety guards in place when the machine is in use. If removed for maintenance purposes, use extreme caution and replace the guards immediately after maintenance is complete.
20. Check damaged guards or parts. Before further use of the machine, carefully check a damaged guard or part to see if it will operate properly and perform its intended function. Check for alignment of moving parts, binding of moving parts, breakage of parts, mounting, and any other conditions that may affect its operation. Properly repair or replace a damaged guard or part that will not operate properly and perform its intended function.
21. Provide for adequate space surrounding work area. Provide non-glare, overhead lighting.
22. Keep blade sharp and properly adjusted for best operation.
23. Keep the floor around the machine clean and free of scrap material, oil and grease.
24. Keep visitors a safe distance from the work area. **Keep children away.**
25. Make your workshop child-proof with padlocks, master switches or by removing starter keys.
26. Do not overload this machine. By overloading the machine, you may cause injury from flying parts.
27. Give your work undivided attention. Looking around, carrying on a conversation and "horse-play" are careless acts that can result in serious injury.

28. Maintain a balanced stance at all times so that you do not fall into the blade or other moving parts. Do not overreach or use excessive force to perform any machine operation.
29. Use the right tool at the correct speed and feed rate. Do not force a tool or attachment to do a job for which it was not designed. The right tool will do the job better and more safely.
30. Dress your work piece edges. Always chamfer and deburr all sharp edges.
31. Use recommended accessories; improper accessories may be hazardous.
32. Maintain tools with care. Keep saw blades sharp and clean for the best and safest performance. Follow instructions for lubricating and changing accessories.
33. This machine is equipped with an emergency stop button. In the event of incorrect operation or dangerous conditions, press the emergency stop button to immediately stop the machine. When the dangerous condition is fixed, twist the emergency stop button clockwise to reset. The machine can be started after the emergency button reset.
34. Turn off the machine before cleaning. Use a brush or compressed air to remove chips or debris — do not use your bare hands.
35. Do not stand on the machine. Serious injury could occur if the machine tips over.
36. Never leave the machine running unattended. Turn the power off and do not leave the machine until it comes to a complete stop.
37. Remove loose items and unnecessary work pieces from the area before starting the machine.
38. Always use push sticks when cutting small material.
39. Raise or lower blade guide only when machine is turned off and blade has stopped moving.
40. Do not allow the saw blade to rest against the workpiece when the saw is not running.
41. The saw must be stopped, and the electrical supply must be cut off before any blade replacement, drive belt replacement, or any periodic service or maintenance is performed on the machine.
42. Remove cut off pieces carefully, keeping hands away from the blade. The saw must be stopped, and the electrical supply cut off or machine unplugged before reaching into the cutting area.
43. Don't use in dangerous environment. Don't use power tools in damp or wet location or expose them to rain. Keep work area well lighted.

Familiarize yourself with the following safety notices used in this manual:

CAUTION This means that if precautions are not heeded, it may result in minor injury and/or possible machine damage.

WARNING This means that if precautions are not heeded, it may result in serious injury or possibly even death.

4.0 About This Manual

This manual is provided by JET covering the safe operation and maintenance procedures for a JET Model VBS-1207VS-DC Band Saw. This manual contains instructions on installation, safety precautions, general operating procedures, maintenance instructions and parts breakdown. Your machine has been designed and constructed to provide consistent, long-term operation if used in accordance with the instructions as set forth in this document.

If there are questions or comments, please contact your local supplier or JET. JET can also be reached at our web site: www.jettools.com.

Retain this manual for future reference. If the machine transfers ownership, the manual should accompany it.

WARNING Read and understand the entire contents of this manual before attempting assembly or operation! Failure to comply may cause serious injury!

Register your product using the mail-in card provided or register online:

www.jettools.com/product-registration

To quickly reach the product registration webpage, scan the QR code below.



5.0 Specifications

Model number VBS-1207VS-DC
Stock number JT1-1375

Electrical

Main Drive Motor 1HP / 220V / 4A / 10P / 3Ph / 2500RPM
Grinder Motor 1/8HP / 110V / 2P / 1Ph / 60Hz / 3450 RPM
Transformer for Welding 1.2KVA / 110V
BLDC Board 1HP / 103-120V / 1Ph Input
Laser 100-240VAC, Class 3A
Power Supply 115V / 1Ph
Full Load 15A

General

Blade Speed Variable Speed BLDC
Speed Range (FPM) 80-1200 FPM
Height Capacity (Max. In.) 6.69" (170mm), Laser Capacity: 4.52" (115mm)
Throat Capacity (Max. In.) 12.2" (310mm)
Table Size (In.) 15.94" x 19.68" (405mm x 500mm)
Table Tilt 45°R / 15°L
Blade Length (Approx. In.) 98.81" – 102.75" (2510 - 2610mm)
Blade Width (Min. – Max. In.) 0.118" – 0.51" (3-13mm)
Blade Thickness 0.025" (0.64mm)
Standard Machine Blade (In.) 0.23" (6mm) 14T
Table Height (In.) 34.84" (885mm)
Blade Wheel Dimension (In.) 12" (310mm)
Belt A54x2
Overall Dimension (In.) 33.07" x 22.83" x 61.42" (840mm x 580mm x 1560mm)
Packaging Dimensions (In.) 36.4" x 24.2" x 68.1" (925mm x 615mm x 1730mm)
Weights:
Net 348 lbs (158.5kg)
Shipping 382 lbs (173.5kg)

The specifications in this manual were current at time of publication, but because of our policy of continuous improvement, JET reserves the right to change specifications at any time and without prior notice, without incurring obligations.

6.0 Uncrating and Checking Contents

▲WARNING Suffocation Hazard!
Immediately discard any plastic bags and packing materials to eliminate choking and suffocation hazards to children and animals.

This machine is shipped complete. Separate all parts from the packing material and carefully check them. Make certain all items are accounted for before discarding any packing material.

IMPORTANT: If any parts are missing, do not place the machine into service until the missing parts are obtained and installed correctly.

Uncrate the band saw. Contact your distributor if any damage has occurred during shipping or if any items are missing.

6.1 Contents

- Bandsaw
- Chip Tray (1) (installed in lower cabinet)
- Hex Bolts (4), M12x45 for Machine Leveling
- Hex Nuts (4), M12 for Machine Leveling

6.2 Cleaning

▲WARNING Do not use gasoline or other petroleum products to clean this machine. They have low flash points and can explode or cause a fire.

▲WARNING When using cleaning solvents, work in a well-ventilated area. Many cleaning solvents are toxic if inhaled.

This machine may be shipped with a rustproof, waxy coating and/or grease on the exposed unpainted metal surfaces. You must completely remove this protective coating using a degreaser or solvent cleaner. Moving items will need to be moved along their travel path to allow for cleaning the entire surface. For a more thorough cleaning, some parts will occasionally have to be removed. Do not use acetone or brake cleaner as they may damage painted surfaces.

6.3 Lifting and Transporting

▲WARNING Lifting and carrying operations should be performed by skilled workers, such as a lift truck operator or crane operator. If a crane is used to lift the machine, attach the lifting chain carefully, making sure the machine is well balanced.

Follow these guidelines when lifting with a truck or trolley:

1. The lift truck must be able to lift at least 1.5 to 2 times the machine's gross weight.
2. Make sure the machine is balanced. While transporting, avoid rough or jerky motion, and maintain a safe clearance zone around the transport area.
3. Use a forklift with sufficient lifting capacity and forks that are long enough to reach the complete width of the machine.
4. Remove the securing bolts that attach the machine to the pallet.
5. Approaching the machine from the side, lift the machine on the frame taking care that there are no cables or pipes in the area of the forks.
6. Move the machine to the required position and lower gently to the floor.
7. Level the machine so that all the supporting screws are taking the weight of the machine and no rocking is taking place. See step 12 in Section 7.0 Installation.

7.0 Installation

Consider the following when looking for a suitable location to place the machine:

1. Overall weight of the machine.
2. Weight of material being processed.
3. Sizes of material to be processed through the machine.
4. Space needed for auxiliary stands, worktables, or other machinery.
5. Clearance from walls and other obstacles.
6. Maintain an adequate working area around the machine for safety.
7. Have the work area well illuminated with proper lighting.
8. Keep the floor free of oil and make sure it is not slippery.
9. Remove scrap and waste materials regularly, and make sure the work area is free from obstructing objects.
10. If long lengths of material are to be fed into the machine, make sure that they will not extend into any aisles.
11. **Floor:** The machine should be placed on a level, concrete floor, capable of supporting the weight of the machine, work stock, and the operator. Provisions for securing it should be in position prior to placing the machine. The accuracy of any machine depends on the precise placement of it to the mounting surface.
12. **Leveling:** This machine distributes a large amount of weight over a small area. The floor should be a level surface. Install the four M12x45 hex bolts and M12 hex nuts to the base flanges as shown in Figure 7-1. To level the machine, place a machinist's level on the table and observe in both directions. Place metal shims under the appropriate leveling

bolts. Tighten hex bolts and nuts and recheck for level. Adjust the leveling bolts and nuts as needed until the table is level.

13. **Working Clearances:** Take into consideration the size of the material to be processed. Make sure that you allow enough space for you to operate the machine freely.
14. **Power Supply Placement:** The power supply should be located close enough to the machine so that the power cord is not in an area where it would cause a tripping hazard. Be sure to observe all electrical codes if installing new circuits and/or outlets.



Figure 7-1 Leveling Bolts and Nuts

7.1 Anchoring the Machine

Follow these guidelines when anchoring the machine to the floor:

1. Once positioned, anchor the machine to the floor, as shown in the diagram. Use bolts and expansion plugs or sunken tie rods that connect through and are sized for the holes in the base of the stand.
2. This machine requires a solid floor such as concrete at a minimum of 4" (102mm) thick. 6" (153mm) minimum is preferred.

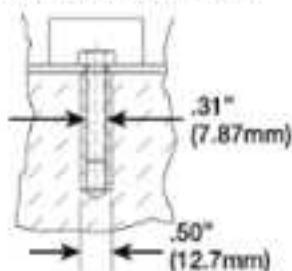

Figure 7-2 Anchoring to Floor

8.0 Electrical Connections

⚠WARNING All electrical connections must be done by a qualified electrician. All adjustments or repairs must be done with machine disconnected from power source. Failure to comply may cause serious injury.

⚠WARNING Make sure the electrical circuit, receptacle, and connections are properly grounded.

The VBS-1207VS-DC Band Saw is rated at 110V, 60Hz alternating current. Verify the input power supply before making any electrical connections. Before connecting the machine to the power source, make sure the power source is OFF.

The band saw must be grounded. A qualified electrician can make the proper electrical connections and confirm the power on site is compatible with the saw.

Before connecting to power source, make sure the OFF button is pressed. Check the voltage and frequency of the power to see if they meet with the requirement, the allowed range for the voltage is $\pm 5\%$, and for the frequency is $\pm 1\%$.

Considerations

- Observe local electrical codes when connecting the machine.
- The circuit should be protected with a time delay fuse or circuit breaker with an amperage rating slightly higher than the full load current of machine.
- A separate electrical circuit should be used for your machine. Before connecting the motor to the power line, make sure the OFF button is pressed in and be sure that the electric current is of the same characteristics as indicated on the machine.
- All line connections should make good contact. Running on low voltage will cause the machine to operate poorly.
- In the event of a malfunction or breakdown, grounding provides a path of least resistance for electric current to reduce the risk of electric shock. This machine is equipped with an electric cord having an equipment-grounding conductor and a grounding plug. The plug must be plugged into a matching outlet that is properly installed and grounded in accordance with all local codes and ordinances.
- Improper connection of the equipment-grounding conductor can result in risk of electric shock. The conductor with insulation having an outer surface that is green with or without yellow stripes is the equipment-grounding conductor. If repair or replacement of the electric cord or plug is necessary, do not connect the equipment-grounding conductor to a live terminal.

- Check with qualified electrician or service personnel if the grounding instructions are not completely understood, or if in doubt as to whether the machine is properly grounded.
- Repair or replace damaged or worn cord.

Extension Cord Safety

Extension cord should be in good condition and meet the minimum wire gauge requirements below:

Ampere Rating		Volts	Total Length of Cord in Feet		
More Than	Not More Than		25	50	100
			AWG		
0	6		18	16	16
6	10		18	16	14
10	12		16	16	14
12	16		14	12	No

Table 1: Extension Cord Recommendations

An undersized cord decreases line voltage, causing loss of power and overheating. All cords should use a ground wire and plug pin.

Power Cord Connection

1. Make sure the OFF button is pressed.
2. Unwrap the power cord and route the cord away from the machine toward the power supply. **IMPORTANT:** Route the power cord so that it will not become entangled in the machine in any way. Do not create a trip hazard with the power cord.
3. Connect the power cord to the power supply and check that the power cord has not been damaged during installation.
4. When the machine is clear of any obstruction, press the ON button to test the operation.
5. Press the OFF button to stop test operation.

9.0 Product and Controls Identification

OVERALL MACHINE

Refer to Figure 9-1



Figure 9-1 Main Product Identification

A - Power Cord: Verify machine power requirements before making connections.

B - Grinder: Grinds welded area of blade back to original material thickness.

C - Blade Welding Station: Welds blade together.

D - Blade Shear: Trims end of blade square prior to welding. Cuts saw bands ranging in width from 0.062" to 1" (1.6mm to 25.4mm) and thickness of 0.025" to 0.035" (0.63mm to 0.89mm).

E - Emergency Stop Switch: Removes power to the operating controls and stops operation.

F - Start/Stop Control: Push buttons to start and run the saw blade and stop the saw blade when the cut is complete.

G - Variable Speed Knob: Changes the speed of the saw blade. Used while the machine is running.

H - Speed Display: Displays the speed of the blade in FPM (Feet Per Minute).

J - Speed Chart Dial: Select speed and pitch for various materials to be cut.

K - Upper Wheel Housing Door: Houses the upper pulley, and tensioner.

L - Guide Post Tension Knob (not visible): Located on the back side of the upper wheel housing, use this to loosen the guide post for adjustment.

M - Guide Post Adjustment Wheel: Use to raise or lower the guide post to provide minimum clearance to the work piece.

N - Work Lamp: Provide additional light to the cut area.

O - Blade Tension Adjustment Wheel: Turn to increase or decrease blade tension.

P - Laser Line Guide: Laser line projects to work piece to show where blade will cut.

Q - Air Tube: Provide air to the work site to blow chip away from cut area.

R - Upper Blade Guide: Holds the blade in position and minimizes blade twist.

S - Work Table: Supports material and provide several ways to control angle cuts.

T - Table Tilt: Trunions used to allow the table to tilt up to 15° left or right.

U - Lower Wheel Housing Door: Houses the drive pulley.

V - Blade Break Sensor: Stops saw if the blade breaks or if the blade tracking is off causing the blade to come off the wheel.

W - Door Limit Switch: There is a door limit switch on both the upper and lower wheel housing doors. These limit switches will stop the saw if either door is opened during operation or prevent the saw from starting if either door is not fully closed.

CONTROL PANEL

Refer to Figure 9-2



Figure 9-2 Control Panel Identification

A - Blade Speed Indicator: Displays the speed of the blade in FPM (Feet Per Minute).

B - Speed Control: This potentiometer will vary the input signal, which in turn will vary the voltage output to the motor, thus controlling the speed of the motor and then the blade.

C - ON Push Button: Press this button to start and run the blade when operating conditions are safe for the blade to move. Make sure the blade is rotating downward towards the work table.

D - STOP Push Button: Press this button to stop the blade any time that the operator is not directly and actively engaged in a cutting operation.

E - Emergency Stop Button (E-Stop): In the event of incorrect operation or dangerous conditions, the machine can be stopped immediately by pressing the **E-STOP** button. Twist the emergency stop button clockwise (cw) to reset. **Note:** Resetting the E-Stop will not start the machine.

WELD STATION

Refer to Figure 9-3



Figure 9-3 Weld Station Identification

A - Welder Controls: The pressure select switch is used to set the pressure or force used to press the ends of the blade together. Press and hold the green weld button to complete the weld. Press and hold the red anneal push button to anneal (cool/harden) the weld.

B - Weld Jaws/Electrodes: The weld jaws clamp and hold the blade in position during the weld. The left jaw moves toward the right with the pressure set on the Pressure Dial. Both jaws are the electrodes which transfer the electrical current to the blade material being welded to create the weld puddle (melted metal) which will flow together to melt the ends together as one piece.

C - Grinder Switch: Toggle the switch to the ON position to start and run the grinding wheel.

D - Grinding Wheel: Grind the blade to remove rough spots and create a smooth surface without making the area thinner than the rest of the blade.

BLADE ADJUSTMENT

Refer to Figure 9-4

A - Blade Tension Handwheel: Turn clockwise to tension blade; counterclockwise to release tension on blade.

B - Upper Guide Post Lock Knob: Turn counterclockwise to loosen guide post. Turn clockwise to lock guide post in place.

C - Upper Guide Post Handwheel: Turn handwheel to raise or lower guide post.

D - Upper Guide Post: Provides blade guard protection and supports the blade.



Figure 9-4 Blade Adjustment Controls

LOWER WHEEL HOUSING

The lower wheel housing has the lower wheel (drive wheel), the debris brush, and the debris tray.

- The lower wheel is the drive wheel which is connected via a shaft to the drive sheave and thus the motor through the drive belt.
- The brush is used to help control / remove chips and metal fillings from getting between the blade and wheel. Keep it clean and adjust as it wears. The bristles should have a slight pressure against the pulley at all times.
- The debris tray will collect larger chips and metal fillings. The tray will slide out and back in for regular cleaning.



Figure 9-5 Lower Wheel Housing

TILTING WORK TABLE

The work table may be tilted from 15° to 45°. The outboard side of the table will lift to create a 15° angle or lowered to a 45° angle.

Tilting the table is done on the back side of the saw. Just under and forward of the degree scale is the clamping nut. Loosen the nut, tilt the table to the desired angle and tighten the nut to hold the angle.



Figure 9-6 Tilting Work Table

UPPER AND LOWER BLADE GUIDES

The blade guides provide side-to-side and back support for keeping the blade straight while cutting material. The blade guides are tungsten steel where they come in contact with the blade to reduce wear on the guides. The guides must be kept properly adjusted for accurate cuts.



Figure 9-7 Upper Blade Guide



Figure 9-8 Lower Blade Guide

10.0 Adjustments

⚠WARNING All adjustments or repairs to machine must be done with power off and machine disconnected from power source. Failure to comply may cause serious injury.

10.1 Blade Tensioning

Refer to Figure 10-1

Without proper tension, a bandsaw blade will not cut efficiently. Too little tension can lead to blade runout, increased wear, and poor finish on the work piece. Too much tension can cause the blade to break. To check the blade tension, you can use a blade tensioner or tension the blade by hand, as explained below.

1. Disconnect power from the bandsaw.
2. Open the upper wheel housing door.
3. Raise upper guide post (C) by loosening guide post lock knob (A) and turning upper guide post handwheel (B) clockwise until it stops.
4. Check the blade deflection at a point halfway between the table and the upper blade guide by applying finger pressure to side of blade. A properly tensioned blade should have a deflection from vertical of approximately 3/8".
5. To increase tension, turn blade tension handwheel (D) clockwise. To decrease tension, turn blade tension handwheel counterclockwise.
6. Measure proper blade tension using the finger pressure method in step 4.
7. After adjusting the blade tension, rotate the top pulley several times by hand and recheck the blade deflection. **NOTE:** When rotating the top pulley, make sure the blade does not touch the flange of the pulley.

IMPORTANT: To prolong the blade life, release the tension on the blade if the bandsaw will be idle for an extended period of time.



Figure 10-1

10.2 Blade Guide Adjustment

Refer to Figure 10-2

CAUTION Blade guides must be properly adjusted or damage may occur to blade and/or guides.

1. Disconnect power from the bandsaw.
2. Check to make sure the guide post is secure, and the blade has been properly tensioned.
3. Using a 5mm hex wrench, loosen the socket cap screws A and B.
4. Slide the blade guide bracket so the blade guides are approximately 0.06" (1.58mm) behind the tooth gullets as shown. Tighten socket cap screw A only. Note: The blade guides need to be adjusted far enough back so they are behind the tooth gullets when the blade is pushed back against the blade support.
5. With socket cap screw B still loose, slide the blade support rod up to, but not touching the back end of the blade. Re-tighten socket cap screw B.
6. Next the blade needs to be centered between the blade guides on both the upper and lower blade guides. To do this, first loosen the socket cap screws C using a 5mm hex wrench. Next, slide a piece of copy machine paper or a dollar bill between each side of the blade guide and the blade. Either of them should be 0.004" (0.1mm) thick. Gently pinch the paper between the blade guides and the blade. Now tighten each socket cap screw C. (Check the position of the air nozzle). The guides should now be positioned correctly without touching the blade.

Note: Over time, the blade inserts will wear. When this happens, flip inserts over and reverse the guides. If the blade wears a groove into the blade support, loosen and rotate it to a new spot.

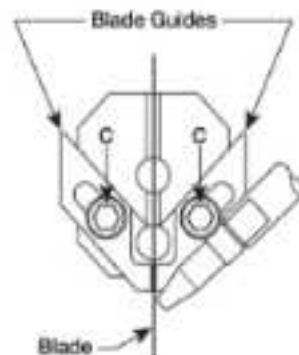
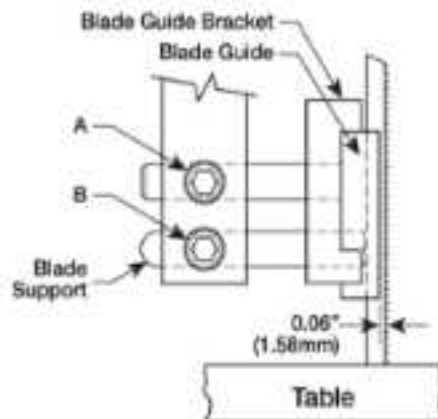

Figure 10-2 Blade Guide Adjustment

10.3 Guide Post Adjustment

Refer to Figure 10-3

The guide post assembly serves two purposes.

- First, it positions the red blade guard between the work piece and the upper pulley housing to protect the operator from the exposed blade.
- Second, it positions the upper blade guides close to the piece part for support of the blade.

To properly position the guide post:

1. Disconnect saw from power source.
2. Loosen the upper guide post lock knob (A).
3. Use the upper guide post handwheel (B) to lower or raise the guide post (C).
4. Locate the bottom of the blade guides 0.25" (6.35mm) above the work piece and securely tighten the upper guide post lock knob.

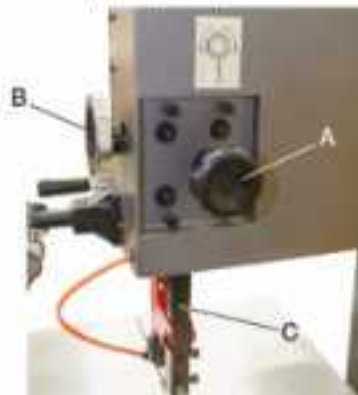

Figure 10-3 Guide Post Adjustment

10.4 Changing Saw Blades

Refer to Figure 10-4

1. Disconnect saw from power source.
2. Open the upper and lower pulley access doors.
3. Release the blade tension by rotating the tension wheel (A) counterclockwise.
4. Put on gloves to protect your hands. Now slide the blade off the upper and lower sheaves, around the blade guards, and through the slot in the table.
5. Install the new blade in the reverse order with the teeth facing forward toward the door and the tips of the teeth pointing downward toward the work table.
6. Make sure the blade is centered on the wheels and engaged between the upper and lower blade guides.
7. Properly tension the blade by following the steps under 10.1 *Blade Tensioning*.



Figure 10-4 Changing Blade

11.0 Blade Selection

Proper blade selection is just as important to band saw operation as is blade speed and material feed. Proper blade selection will impact blade life, straightness of cut, cut finish, and efficiency of operation. Excessive blade breakage, stripping of teeth, and waviness of cut are some of the results of improper blade selection.

Blades are classified by material composition, tooth shape, tooth pitch, tooth set, gage of the band material, and kerf of the set (width of cut).

11.1 Material Composition

Carbon Steel – low cost, for use with non-ferrous materials, wood, and plastics.

High Speed Steel – resists heat generated by dry cutting. Used for ferrous metals.

Alloy Steel – tough and wear resistant, cuts faster with longer blade life. Used on hard materials. More expensive than carbon or high speed steel.

Carbide Tipped – for cutting unusual materials such as uranium, titanium, or beryllium.

11.2 Tooth Shape

Note: When cutting thin materials, the rule for blade pitch is to have a minimum of two teeth engaging the material being cut at all times.

Standard Tooth - generally used to cut ferrous metals, hard bronze, hard brass, and thin metals.

Skip Tooth - have better chip clearance (larger gullet) and are used on softer, non-ferrous materials such as aluminum, copper, magnesium, and soft brass.

Hook Tooth - provides a chip breaker and has less tendency to gum up in softer materials. Used in the same materials as skip tooth but can be fed faster than standard or skip tooth blades.

11.3 Set Type

Straight Set – used for free cutting non-ferrous materials; i.e., aluminum, magnesium, plastics, and wood.

Wavy Set – used on materials of varying thickness (pipe, tubing, and structural shapes).

Raker Set – used in large cuts on thick plate and bar stock where finish of cut is not as important as speed.

11.4 Blade Terminology

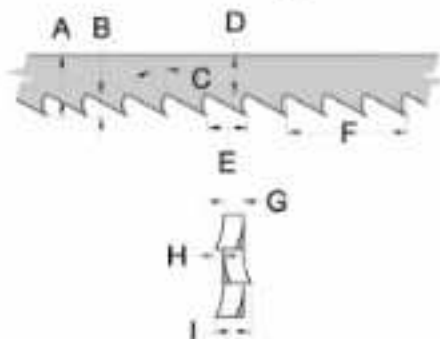

Figure 11-1 Blade Terminology

A – Width: The thinner the blade, the tighter will be the minimum radius of cut. Usually, a wider blade will cut straighter and more accurately. Always use widest blade possible for the job.

B – Gullet Depth: The distance from the tooth tip to the bottom of the curved area.

C – Tooth Rake: The angle of the tooth face from a line perpendicular to the length of the blade.

D – Blade Back: The distance between the back edge of the blade and the bottom of the gullet.

E – Tooth Pitch: The distance between tooth tips.

F – TPI: The number of teeth per inch when measured from gullet to gullet.

G – Gauge: Gauge is the thickness of the blade. Thicker blades are stronger.

H – Tooth Set: The distance a tooth is bent from the blade.

I – Kerf: Kerf is the width of a cut. Kerf will vary according to the set of the blade teeth.

11.5 Breaking in a Band Saw Blade

Sharp cutting edges with extremely small edge radii are required for high cutting capacity. To achieve the optimal tool life, we recommend breaking-in the blade accordingly. The correct cutting speed is determined by the material being cut and its dimensions. It is very important that the new blade is first used with only 50% of the determined feed rate. This will avoid micro-breakages of the blade because of too large chip thicknesses. New band saw blades may tend toward vibrations and vibration sounds. In this case a slight reduction of the cutting speed is helpful. With small workpiece dimensions, approximately 300cm² of the material should be cut for breaking-in. If large work piece dimensions are to be cut, we recommend a breaking-in period of about 15 minutes. After breaking-in you may slowly increase the feed rate up to the determined value.

11.6 Metal Chip Indicators

Chips are the best indicator of correct material feed force. Monitor chip information and adjust feed accordingly.

- Thin or Powdered Chips – increase feed rate or reduce saw speed
- Burned Chips – reduce feed rate and / or saw speed
- Curly Silvery and Warm Chips – optimum feed rate and saw speed

11.7 Blade Care

The bandsaw blade is subjected to a tremendous amount of strain. Make sure to always use the appropriate feed rate for the type of material you are cutting.

Be sure to select a blade of the proper width, style, and pitch that will produce the best cut in your material. Choosing the wrong blade can produce excess heat that can adversely affect the life of the blade.

A clean blade performs much better than one that is dirty. Blades that are gummed up and dirty offer more resistance when cutting through the material. This in turn creates unnecessary heat in the blade.

11.8 Blade Breakage

Band saw blades are subject to high stresses and breakage may sometimes be unavoidable. However, many factors can be controlled to help prevent most blade breakage. Here are some common causes for breakage:

1. Misalignment of blade guides.
2. Feeding workpiece too quickly.
3. Using a wide blade to cut a short radius curve.
4. Excessive tension.
5. Teeth are dull or improperly set.
6. Upper guides are set too high off the workpiece.
7. Faulty weld on blade.

12.0 Band Saw Operation

▲WARNING Wear eye protection while operating bandsaw. The bandsaw blade is sharp and will cut fingers and hands. Keep all body parts away from the saw blade. Use a block of wood as a pusher for the material being cut. Always wear leather gloves when working near the blade.

▲WARNING Never operate band saw without blade and wheel covers in place and secured.

12.1 Before Each Use

- For dusty operations, wear a face shield along with safety goggles.
- It is important to choose the right blade for the material and the type of cutting you plan to do. This saw is equipped with a bi-metallic blade which can be used to cut stainless steel, steel, iron, brass, aluminum, wood, plastic.
- Make sure the direction of rotation arrow on the blade matches the direction arrow on the saw. The blade teeth should always point downward at the front of the saw.
- Make sure the blade is sharp, undamaged and properly aligned. With the saw unplugged, rotate the blade by hand checking for clearance. If the blade hits anything, make proper adjustments as needed.
- Make sure the cut-off piece can move sideways after it is cut off.
- Never turn the saw "ON" before clearing everything from the table.
- Never put lubricants on the blade while it is spinning.

12.2 While Saw is Running

- Never confine the piece being cut out.
- Never clamp it, touch it, or use length stops against it. It must be free to move sideways. If confined, it could get wedged against the blade and thrown violently.
- Avoid awkward hand positions where a sudden slip could cause a hand to move into the blade.
- Let the blade reach full speed before cutting.
- Feed the work piece into the saw only fast enough to let the blade cut without bogging down or binding.
- Before freeing jammed material, press the OFF button and unplug the saw. Wait for all moving parts to stop.
- After finishing a cut, press the OFF button and wait for all moving parts to stop before removing any cut pieces.

12.3 Blade Break-In Procedure

New blades are very sharp and therefore have a tooth geometry that is easily damaged if a careful break-in procedure is not followed. Consult the blade manufacturer's literature for break-in of specific blades on specific materials. The following procedure will be adequate for break-in of JET-supplied blades on lower alloy ferrous materials.

1. Follow operating procedures in 12.6 *Basic Operating Procedure*.
2. Use a section of round stock.
3. Operate the saw at low speed. Start the cut with a very light feed rate.
4. When the saw has completed about 1/3 of the cut, increase the feed rate slightly and allow the saw to complete the cut.
5. Keep the feed rate at the same setting and begin a second cut on the same or similar workpiece.
6. When the saw has completed about 1/3 of the cut, increase the feed rate while watching the chip formation until cutting is at its most efficient rate (refer to 12.4 *Evaluating Cutting Efficiency*). Allow the saw to complete the cut.
7. The blade is now considered ready for use.

12.4 Evaluating Cutting Efficiency

The best way to determine whether a blade is cutting efficiently is to observe the chips formed by the cutting.

- If chip formation is powdery, then the feed rate is too light, or blade is dull.
- If the chips formed are curled, but colored – blue or straw colored from heat generated during the cut – then feed rate is excessive.
- If chips are slightly curled and not colored by heat, then the blade is sufficiently sharp and is cutting at its most efficient rate.

12.5 Material Selection

▲WARNING Make sure materials being processed through this machine are not potentially hazardous to the operator or people working nearby.

When selecting materials keep these instructions in mind:

- Material must be clean and dry. (without oil)
- Material should have a smooth surface, so it processes easily.
- Dimensional properties of material must be consistent and not exceed the machine capacity values.
- Chemical structure of material must be consistent.
- Buy certificated steel from the same vendor when possible.

12.6 Basic Operating Procedure

1. Verify the work area including the table is clear of obstructions.
2. Make sure upper and lower wheel housing doors are closed. There are door limit switches on each door which prevent the machine from operating if the doors are not closed.
3. Set the guide post (A) to approximately 25" (6.35mm) above the piece part and tighten the guide post knob.
4. Set the table angle for the desired cut. Have a push block within reach without crossing the blade path or vision of the cut area. Simulating the cut without power may be helpful.
5. Set the work lamp (B) position to provide additional light at the cut site without interfering with the material or the ability to maintain control of the material for the entire cut.
6. Have proper support for the material to be cut. This should include both the finished piece and the excess material.
7. Press the ON button (C) to starting blade movement. If any abnormal sounds or vibrations are noticed, press the red stop button (D) immediately.
8. Adjust the variable speed dial (E) until the desired speed is indicated on the speed display (F). Refer to Speed & Pitch Selector dial (G) on upper wheel housing door.
9. Carefully place the material on the table.
10. When positioned, feed the material into the blade using a steady smooth motion.
11. When the cut is complete, press the red stop button (D) on the control panel and wait until the blade stops before removing any material near the blade.
12. After pressing stop button, the DRO will flash "UV" (under voltage). The DRO must clear and be blank before restarting machine.



Figure 12-1

13.0 Welder Operation

▲WARNING The electrical current that flows through the blade welder when operating could cause serious personal injury or death. To avoid the risk of electrocution, never touch any metal part of the weld station during welding or annealing of the blade.

▲WARNING Wear eye protection while operating welder. The bandsaw blade is sharp and will cut fingers and hands. Use care when handling blade.

▲WARNING A newly-welded blade is very hot. Wear heat resistant gloves when handling a newly-welded blade.

Overall Description

The weld station can butt weld and anneal blades from 0.118" (3mm) to 0.625" (16mm) wide by 0.032" (0.8mm) thick. It is a resistance type welder with two jaws that secure the blade ends during the welding process. A selector knob is turned counterclockwise to pre-load the left jaw, forcing the blade ends against one another. When the operator presses the weld button, electric current passes through the butted blade ends. The left jaw blade end is pushed into the molten puddle and welded to the right blade end. Remove the blade from the jaws if any weld flash is present and carefully grind it off. The blade joint must now be placed back into the jaws where annealing of the weld joint takes place. This procedure will reheat the weld area so it is not so brittle and should return it to its original condition.

It may become necessary to weld blades when:

- They break unexpectedly and the teeth are still sharp enough to cut.
- You need to make blades from a bulk saw blade coil.
- When you need to weld a blade that was cut to make an internal contour cut on a piece part.

13.1 Preparing the Saw Blade Prior to Welding

▲WARNING Shear hazard. Keep hand and fingers away from shear blade.

Blade Shear: Use the blade shear to cut the band apart or to cut the band to a specified length. The shear is capable of cutting saw blades from 0.118" to .625" (3mm to 16mm) in width and 0.025" to 0.035" (0.63mm to 0.89mm) in thickness. To use the blade shear, raise the handle, insert the blade perpendicular to the cutting knife, and make the cut (see Figure 13-1).

Removing Teeth: In fine pitched blades, one or more of the teeth on each side of the cut may need

to be removed by grinding so that the weld area of the blade is uniform, and the teeth will be uniformly spaced (see Figure 13-2).

Squaring Ends: If the saw band cut is not square after shearing, use the grinding wheel to square it up. Take small cuts so as not to overheat the blade band. To get both ends of the band to match perfectly, twist it and hold the ends so that the teeth are on opposite sides and pointing in opposite directions. Now grind as shown in Figure 13-3.



Figure 13-1

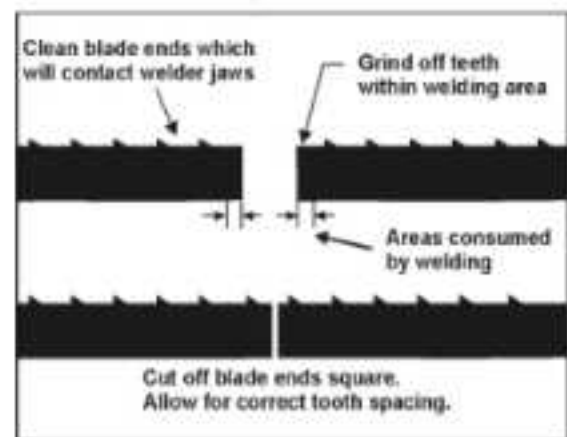

Figure 13-2

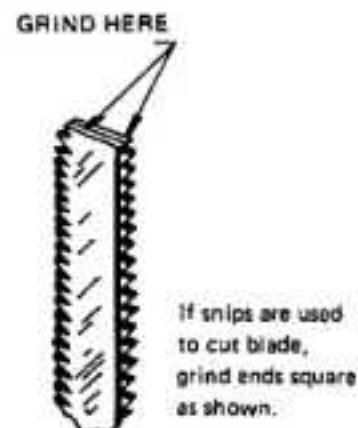

Figure 13-3

13.2 Welding

▲WARNING The electrical current that flows through the blade welder when operating could cause serious personal injury or death. To avoid the risk of electrocution, never touch any metal part of the weld station during welding or annealing of the blade.

▲CAUTION The welder is designed for intermittent use. Repeated welding within a short period of time may cause welder to overheat.

13.2.1 Preparing the Blade Welder

Refer to Figure 13-4

1. Clean welder jaws (A & C) to ensure good electrical contact.
2. Check that the jaws will adequately hold the thickness of the blade you are welding.
3. The blade should slide easily in the left jaw before turning the weld force selector switch (E).
4. Check the grinding wheel (G) and make sure it is in good condition.

13.2.2 Making the Weld

Refer to Figure 13-4

▲WARNING A newly-welded blade is very hot. Wear heat resistant gloves when handling a newly-welded blade.

1. Before making a weld, turn off band saw motor by pressing the red STOP button on the band saw control panel.
2. Carefully clean ends of blade which will contact welder jaws. Remove any dirt, oil, scale and oxide.

▲CAUTION Any rust (oxide) on blade in vicinity of weld must be ground off before blade can be welded.

3. Turn weld pressure selector switch (E) to "0" position (pointed downward). NOTE: There will be some resistance when turning knob.
4. Make sure the blade ends are squared and ready for welding. See 13.1 *Preparing the Saw Blade Prior to Welding*.
5. Insert one end of blade into left weld jaw (A). Position back edge of blade against back edge of left jaw and slide the end of the blade midway between left (A) and right (C) jaws. Tighten left jaw clamp (B).
6. Insert opposite end of blade into right clamp (C). Position back edge of blade against back

edge of right clamp. Slide the butt the end of blade against the other end of blade. Make sure the blade ends fit together with no gap (the blade ends need to be in contact with each other). If a gap is present, remove the blade and re-square the ends. If no gaps are found, tighten right clamp (D).

7. The pressure selector switch (E) is used to apply the necessary pressure to hold the ends of the blade together during welding. Follow these steps to set the pressure selector switch correctly:

- A. **Determine Blade Width:** Measure the width of the blade you are welding.
- B. **Adjust Pressure Selector:** Rotate the pressure selector switch counterclockwise to the setting that corresponds to the blade width.
 - **Pressure Setting Guide:** Every 5/64" (2mm) of blade width requires one pressure setting increment.
 - **Example:** For a blade width of 1/4" (6.3mm), set the pressure selector to 3.

NOTE: The wider the blade, the higher the pressure setting needed.

▲WARNING Sparks from the blade welding operation can be thrown in all directions and can cause serious personal injury or fire. When using the blade welder, always protect yourself and others from flying sparks. Keep fire extinguishing equipment close by and do not weld near flammables.

8. Press and hold the green weld button (F). When weld button is pushed, the left clamp moves to the right to apply pressure to the blade ends. Simultaneously, sparks will be emitted from the blade ends as they are being welded. Do not release weld button until blade joint is "red hot."

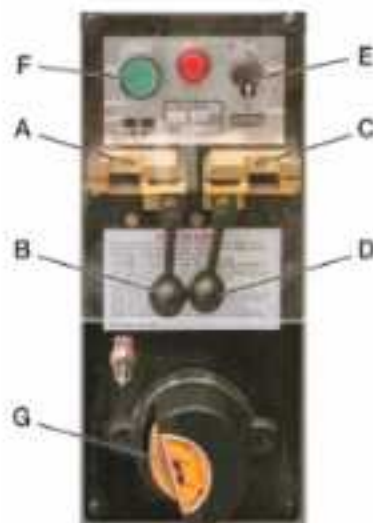

Figure 13-4

9. Release weld button (F) and wait 3 or 4 seconds until blade returns to original color. Unclamp blade.
10. Rotate pressure selector switch (E) back to "0".
11. Remove blade from welder jaws, and carefully inspect it. The spacing of the teeth should be uniform and the weld should be located in center of gullet. Misalignment is easily noted at this time from the weld appearance. See Figure 13-5 for examples of incorrect welds.
12. If the weld is imperfect, refer to section 15.4 for possible remedies to any problems. Make corrections before annealing. If you see what appears to be an excessive amount of flashing, you can try selecting a lower weld force setting.

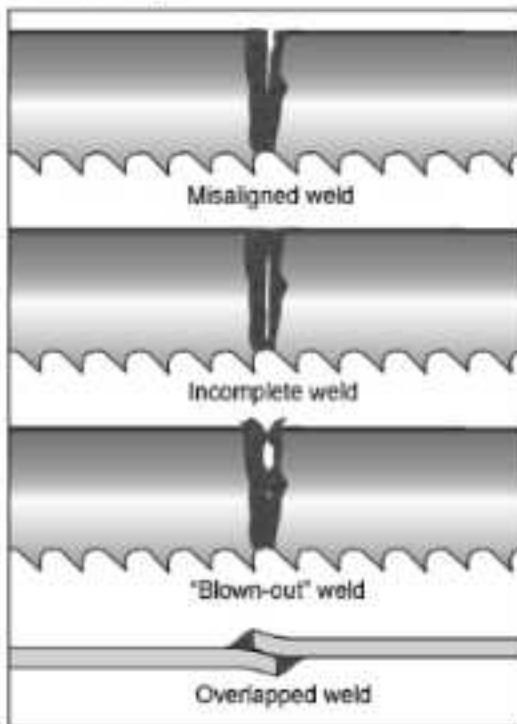

Figure 13-5

13.3 Annealing

Refer to Figure 13-6

WARNING A newly-welded blade is very hot. Wear heat resistant gloves when handling a newly-welded blade.

The blade must now be annealed or cooled at a controlled rate to prevent it becoming too brittle.

The general procedure follows. Specific procedure will depend upon blade type, as described in sections 13.3.1 through 13.3.3.

1. Turn pressure selector switch (E) all the way to left so welder jaws are closest to each other.
2. Insert blade into welder jaws (A & C) so that weld area is centered between clamps. Secure blade in jaws with the clamp handles (B & D).

3. Quickly and repeatedly press the red anneal button (G) with a few short bursts to make the weld area a dull orangish-red. The wider the blade, the more bursts and time it will take.

CAUTION Do not press and hold the anneal push button. The weld will be overheated and will fail due to excessive heat.

4. Allow the welded area to cool 15-30 seconds and then repeat the annealing process twice more.
5. Release both blade clamps, allow blade to cool, then remove blade from clamps.
6. Check weld integrity. Bend blade to form a radius at point of weld. The size of the radius should be approximately the same as radius of band saw drive wheel. The weld must hold and not break or crack after forming the radius. If the weld breaks, cut away welded area and repeat welding-annealing process.
7. Check to make sure welded section is same thickness as rest of blade. If not, grind off excess weld material using the grinder. Refer to section 13.4, *Blade Grinding*.

CAUTION If blade is thicker at the weld than at the rest of the blade, using the blade may damage the guides.

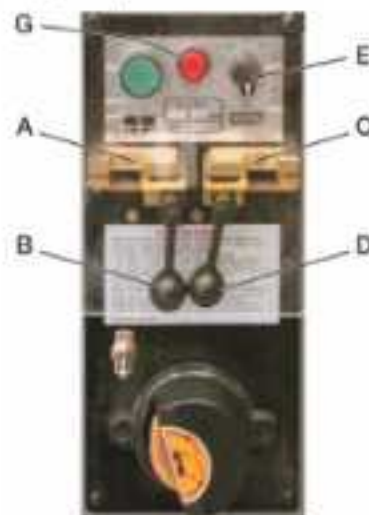

Figure 13-6

IMPORTANT: The following are variations of the general procedure, based upon blade type:

13.3.1 Carbon Steel Blades

1. Press and jog the annealing switch button until weld is a "dull cherry" to "cherry red" color.
2. Allow blade to cool slowly by decreasing jogging frequency.

13.3.2 Carbon Steel Hard Back Blades

1. Heat blade slowly until weld becomes a deep blue color.
2. Continue to heat by jogging the anneal button until the width of the blue color is one-half the length of the band exposed between the jaws.
3. Do not overheat or the temper of the band will be damaged. **Caution - Do not heat beyond the "blue" stage.** If the band begins to show any red color, it is too hot. Cool quickly by releasing the anneal button.

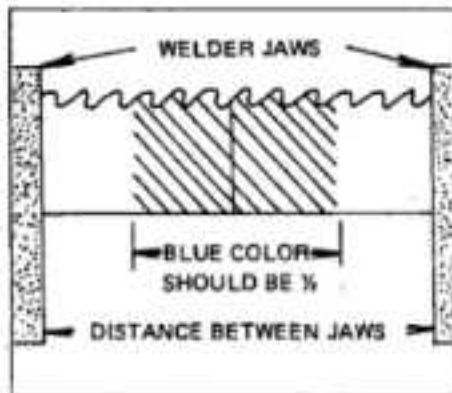

Correct annealing of Carbon Steel Hard Back Blades

Figure 13-7

13.3.3 Bi-Metal Blades

1. Heat blade slowly by jogging the annealing switch button until weld just begins to emit light (dull red color). The desired color may not always be visible in normal room light - always shade the weld area with your hand.
2. Cool the weld quickly by releasing the annealing button.
3. Follow this procedure before and after grinding bimetal blades.

13.4 Blade Grinding

⚠WARNING Keep hands away from rotating grinding wheel. Failure to comply may cause serious injury. Always heed the indicator light - when glowing, it warns that the grinder motor is running.

After annealing, the blade must be ground to remove excess metal or flash from the weld. With the teeth facing out, grind the weld carefully (see Figure 13-8). Do not hit the teeth, or grind deeper than the weld, burn, or overheat the weld area. Be sure to remove flash from back edge of blade. Any flash or "stub" teeth which project beyond the normal set or height of the other teeth must be ground off.

Figure 13-9 illustrates some unacceptable grindings.



Figure 13-8

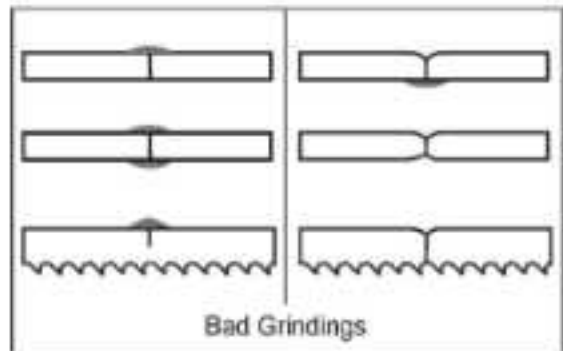

Figure 13-9

13.5 Secondary Annealing

Anneal the weld 2 to 3 times again after grinding.

13.6 Welder Clean-Up

It is important that the welder jaws be kept clean at all times. The jaws and inserts must be wiped or scraped clean after every weld. Doing this will ensure better welds by:

1. Holding proper alignment.
2. Preventing flash from becoming embedded in the blade.
3. Preventing shorts or poor electrical contact.

14.0 Maintenance

▲WARNING Before doing maintenance on the machine, disconnect it from the electrical supply. Failure to comply may cause serious injury.

IMPORTANT: Proper maintenance can increase the life expectancy of your machine.

14.1 Daily Maintenance

Use a brush to loosen accumulated chips and debris. Use a shop vacuum to remove the debris. Make sure the chip brush on the lower band wheel is clean and properly adjusted.

Inspect the saw blade for wear. Replace blade if needed.

Check that the blade guards are in place and in good condition. Make sure the emergency stop button works properly.

If the power cord is worn, cut, or damaged in any way, have it replaced immediately.

Wipe off the rubber tires and clean the table after each day's use.

14.2 Weekly Maintenance

Thoroughly clean the machine.

Remove chips from inside the guard housing for the saw blade.

IMPORTANT: When cleaning chips and debris from the machine, use a brush and a shop vacuum. Do not blow off the machine with compressed air. The force of the compressed air may force chips into critical mechanisms or may inflict injury to yourself or others.

14.3 Monthly Maintenance

Tighten any loose bolts, nuts, or screws on the machine.

Re-grease the drive bearings.

Inspect the blade brush for wear. Adjust or replace if needed.

Grease the pivot of the blade shear.

Wipe shafts and threaded rods with a light lubricant.

Inspect the V-belts for wear (every 3 months).

14.4 Lubrication Schedule

- **Blade Shear Lubrication** – Apply a light coating of grease to the pivot mechanism as needed.
- **Upper Wheel Housing Items** – Apply grease to the tension adjustment screw (A) and the blade guide post rack (B) as needed to keep them moving freely and free of rust.



Figure 14-1

- **Table Support Lubrication** – Grease the pivoting table support as often as needed.

15.0 Troubleshooting

15.1 Driver Error Codes

Table 2

Code	Description	Possible Cause	Troubleshoot Problems
UV	Low voltage protection.	Input voltage too low.	Check the power supply.
OV	Overload voltage protection.	1. Main power input over limit voltage. 2. Over motor allowance rate ampere.	1. Check main power voltage between 104-120V(12"/18"), 208-230V (20"). 2. Slowly turn the speed control knob to low speed.
OCA	Speed up overload protection.	1. Over motor rate load capacity, 2. Cord damaged. 3. Acceleration or deceleration time is too fast (turning speed control knob too fast).	1. Reduce load. 2. Check for broken input/output wires. Replace if broken or damaged. 3. Turn speed control knob more slowly.
OCD	Slow down speed overload protection.		
OCR	Overcurrent protection during operation.		
CCA	Current (ampere) limit protection at acceleration.		
CCD	Current (ampere) limiting protection during deceleration.		
CCR	Current (ampere) limiting protection during running.		
OH1	Driver overheat protection.	1. PCB rate temperature too high. 2. Cooling fan stopped.	1. Stop machine and cool down 20 min. before restarting. 2. Replace new cooling fan.
OH2	Motor overheat protection.	1. Overload of the motor rate temperature capacity.	1. Stop machine and cool down 20 min. before restart.
OL1	Motor overload protection.	1. Overload of the motor allowance ampere.	1. Reduce load when cutting. 2. Check motor rate ampere
OL2	Driver overload protection.	1. Overload of the PCB allowance capacity. 2. Acceleration, deceleration time and load cycle are too long.	1. Reduce load. 2. Increase acceleration/ deceleration time. 3. Replace new driver.
EPR	Memory access abnormality.	Abnormal data in memory.	Replace new PCB driver.
CTR	Current loop detection abnormality.	The current loop hardware circuit is damaged or abnormal.	Replace new PCB driver or contact Technical Service.
ASR	Encoder feedback abnormality.	The motor encoder wires is disconnected and the installation position is offset.	1. Check whether the wiring is disconnected. 2. Contact Technical Service.

15.2 Operating Problems

Table 3

Trouble	Probable Cause	Remedy
Saw blade is twisted.	Blade has been improperly welded.	Re-weld blade. See <i>Section 13.0 Welder Operation</i> .
	Blade not installed properly.	Follow instructions in <i>Section 10.5 Changing Saw Blades</i> .
	Feeding workpiece too forcefully.	Decrease feed rate.
	Incorrect choice of blade.	Use proper width blade for radius or wavy line cutting.
Cuts not straight.	Blade tooth has improper set.	File to proper set or replace blade.
	Inadequate blade tension.	Increase tension.
	Guide post too high.	Set guide post .25" (6.35mm) above workpiece.
	Feed rate too strong.	Decrease feed rate.
Blade slips off wheel(s).	Inadequate blade tension.	Increase tension.
	Wheels not aligned properly.	Contact technical service for adjustment of wheel alignment.
Blade quickly becomes dull.	Blade speed too fast.	Use slower speed.
	Wrong blade for the job.	Use proper blade for workpiece.
	Feed rate excessive.	Decrease feed rate.
Blade warps.	Dull blade.	Sharpen or replace blade.
	Guide post not fixed properly.	Fix guide post in position.
	Blade not tensioned enough.	Increase tension.
	Blade not 90° to table.	Adjust table perpendicular to blade.
Band Saw is noisy or vibrates too much.	Band Saw not resting on level surface.	Floor must be flat.
	Variable speed pulley is damaged.	Replace pulley.
Blade teeth keep breaking.	Incorrect blade for the job.	Select proper blade pitch and style.
	Blade is of inferior material.	Use better quality blade.
Blade becomes damaged easily.	Blade has been over-annealed.	Decrease annealing temperature.
	Too large a gap between blade guides and blades.	Adjust proper gap between guides and blade. See section 10.3.
	Blade too wide for short radius cutting.	Select narrower blade appropriate to the job.

15.3 Mechanical and Electrical Problems

Table 4

Trouble	Probable Cause	Remedy
Machine will not start/restart, stops during operation, or repeatedly trips circuit breaker or blows fuses.	No incoming power.	Verify machine is connected to power source. Make sure ON button is pushed in completely, and STOP button is disengaged.
	Door limit switches not touching upper or lower wheel housing doors.	Make sure upper and lower wheel housing doors are completely closed.
	Cord damaged.	Replace cord.
	Low voltage/current.	Contact a qualified electrician.
	Blade has broken or slipped off wheel, activating the blade break sensor, causing the machine to not start or shut down.	Replace broken blade or reinstall blade and adjust for correct tracking.
	Blade break sensor is damaged or bad.	Check blade break sensor. Replace if needed.
	Blade break sensor is misaligned.	Check mounting of blade break sensor. Realign to make sure sensor surface is next to flat side of blade and mounting screws are tight. Set gap between sensor and blade to 2-3mm.
	Overload automatic reset has not reset.	When the band saw overloads on the circuit breaker built into the motor starter, it may take time for the machine to cool down before restart. Allow unit to adequately cool before attempting restart.
	Band Saw frequently trips.	One cause of overloading trips which are not electrical in nature is too heavy a cut. The solution is to reduce feed pressure into the blade.
	Building circuit breaker trips or fuse blows.	Verify that band saw is on a circuit of correct size. If circuit size is correct, there is probably a loose electrical lead.
	Motor overheated.	Clean motor of dust or debris to allow proper air circulation. Allow motor to cool down before restarting.
	Switch or motor failure (how to distinguish).	If you have access to a voltmeter, you can separate a driver failure from a motor failure by first, verifying incoming voltage at 120+/-10% and second, checking the voltage between driver and motor at 220+/-10%. If incoming voltage is incorrect, you have a power supply problem. If voltage between driver and motor is incorrect, you have a driver problem. If voltage between driver and motor is correct, you have a motor problem.
Motor failure.	If electric motor is suspect, you have two options: Have a qualified electrician test the motor for function or remove the motor and take it to a qualified electric motor repair shop and have it tested.	
Switch failure.	If switch is suspect, you have two options: Have a qualified electrician test the switch for function, or purchase a new start switch and establish if that was the problem on changeout.	
Band Saw does not come up to speed.	Extension cord too light or too long.	Replace with adequate size and length cord.
	Low voltage.	Contact a qualified electrician.

15.4 Welded Blade Inspection

Table 5

Trouble	Probable Cause	Remedy
Weld is misaligned.	Dirt or scale on welder jaws or blade.	Always keep jaws clean. Clean blade before welding.
	Blade ends not square.	Before welding, grind cut edges of blade until they are square. Use the shear on the band saw for square cuts.
	Blade ends not correctly aligned when clamped in jaws.	Align ends properly before clamping.
	Worn welder jaws	Replace welder jaws.
	Welder jaws not aligned correctly.	Align jaws correctly.
Misaligned weld: Blade ends are overlapped.	Pressure select switch is set for wider blade than the one used.	Adjust pressure select switch correctly for particular blade width.
	Blade ends or welder jaws not aligned correctly.	Make corrections as needed.
Weld breaks when used.	Weld is weak and incomplete; possible "blow holes" (see Figure 13-5).	Cut and re-weld blade ends.
	Weld has been ground too thin.	Cut and re-weld blade ends.
	Weld incorrectly annealed.	Follow annealing instructions in section 13.3.
Incomplete weld.	Pressure select switch not set correctly.	Make appropriate adjustment
	Improper clamping procedures.	Use proper procedures. See section 13.0.
	Limit switch not adjusted correctly.	Adjust limit switch correctly.
	Defective limit switch; doesn't break circuit at end of welding operation.	Replace limit switch.
	Welder jaw movement obstructed by kinked jaw cable or tangled wires.	Bend cable and untangle wires.
Brittle weld.	Incorrect annealing heat.	Bring weld up to correct color. See section 13.3.
	Scale or oil on weld caused poor annealing.	Keep welder jaws and blade clean.

15.5 Welder Mechanical Problems

Table 6

Trouble	Probable Cause	Remedy
Weld could not be made. Jaws do not move.	Wire connection is poor; connecting point of welding switch is bad.	Change switch or grind the connecting port with a file.
	Transformer burned out.	Change transformer or rewire it.
	Blade has oil on it.	Wipe off any oil.
	Blade ends have rust.	Grind off rust.
Weld area melts when weld button is pushed.	Welding button is cutting off late.	Screw welding switch connecting nut tighter.
	Welding pressure too weak.	Rotate pressure selector switch accordingly.
	Jaw movement too slow.	Put some oil on rear side of welding lever and the two jaws.
Blade cannot be tightly clamped with the welder jaws.	Welder jaws are out of order or decayed.	Replace welder jaws.
	Lower jaw inserts are out of order.	Replace lower jaw inserts.
Annealing doesn't occur when annealing button is pushed.	Annealing switch connection is poor.	Replace annealing switch.
	Fuse blown.	Replace fuse.
Annealing button will not return to correct position after release.	Annealing button has dust or debris around it.	Remove annealing button housing and clean out any dust or debris.
Grinder will not run when grinder switch is pushed.	Grinder motor is burned out.	Change grinder motor or rewire it.
	Grinder switch is bad.	Replace grinder switch.

16.0 Typical Band Saw Operations

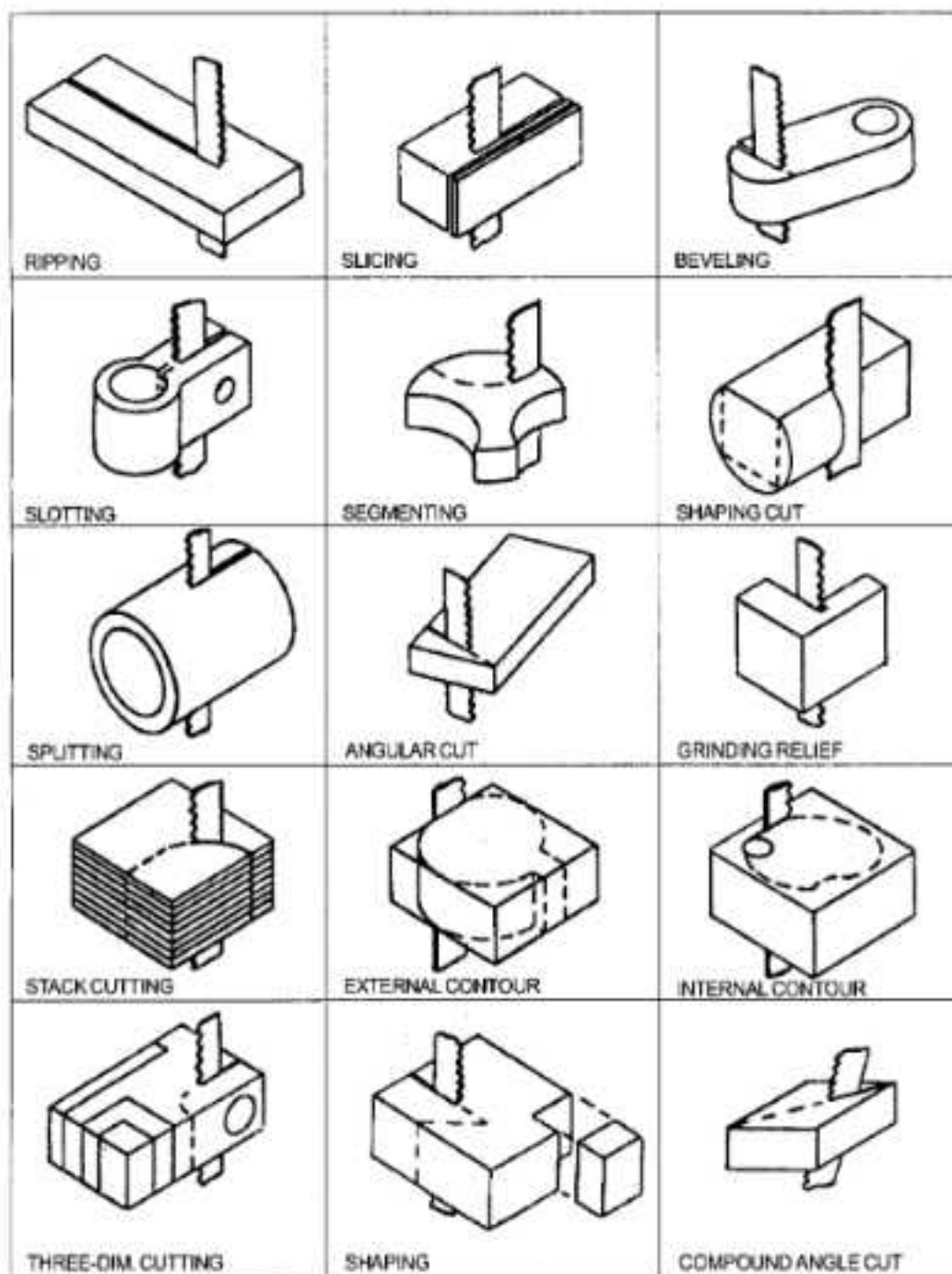

Figure 16-1

17.0 Replacement Parts

Replacement parts are listed on the following pages. To order parts or reach our service department, call 1-800-274-6848 Monday through Friday, 8:00 a.m. to 5:00 p.m. CST. Having the Model Number and Serial Number of your machine available when you call will allow us to serve you quickly and accurately.

Non-proprietary parts, such as fasteners, can be found at local hardware stores, or may be ordered from JET. Some parts are shown for reference only, and may not be available individually.

Note: An asterisk in the parts list indicates the part belongs to a complete assembly.

17.1.1 VBS-1207VS-DC Cabinet Assembly – Exploded View

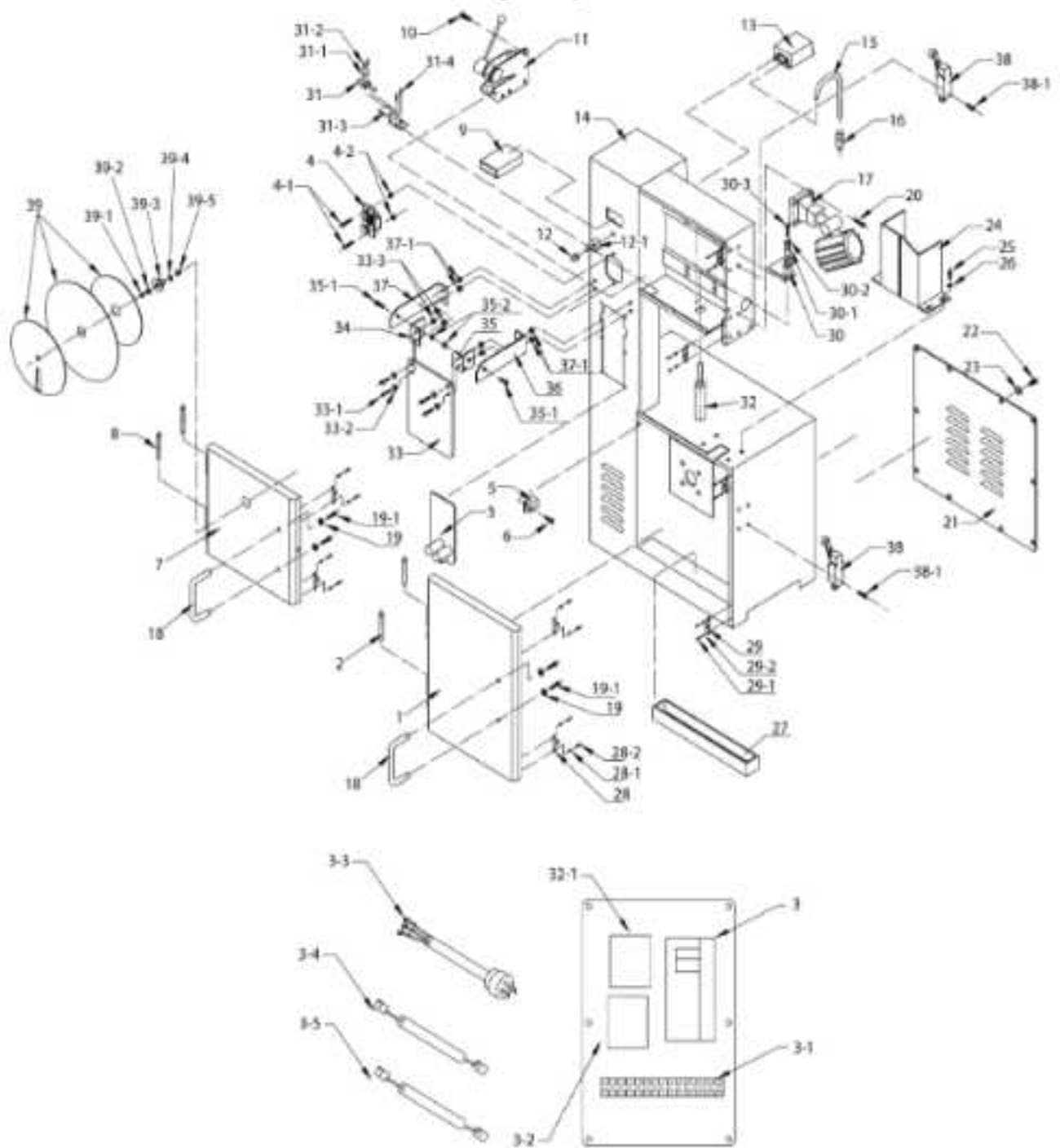

17.1.2 VBS-1207VS-DC Guide Post & Work Table Assembly – Exploded View

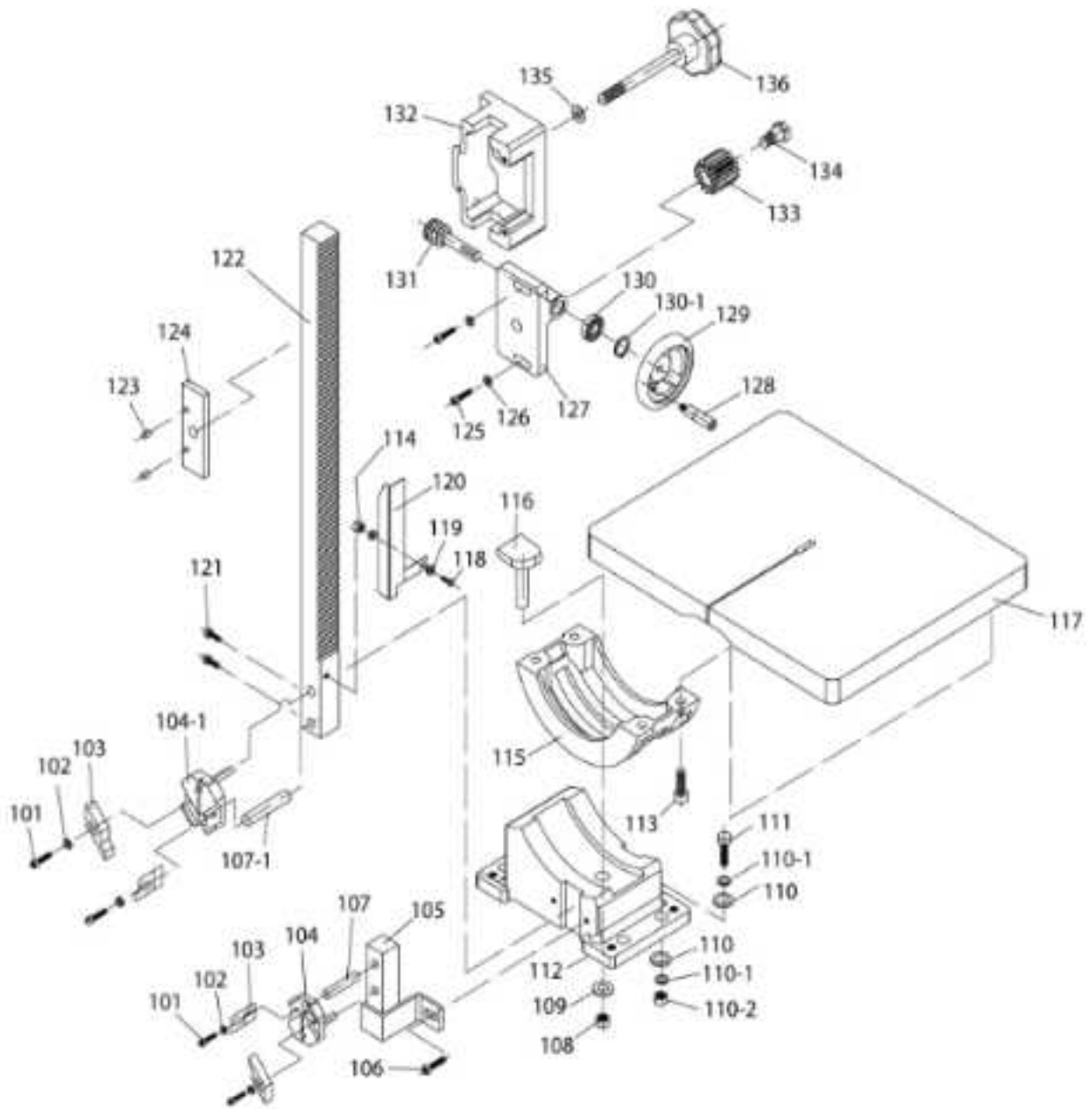

17.1.3 VBS-1207VS-DC Drive System Assembly – Exploded View

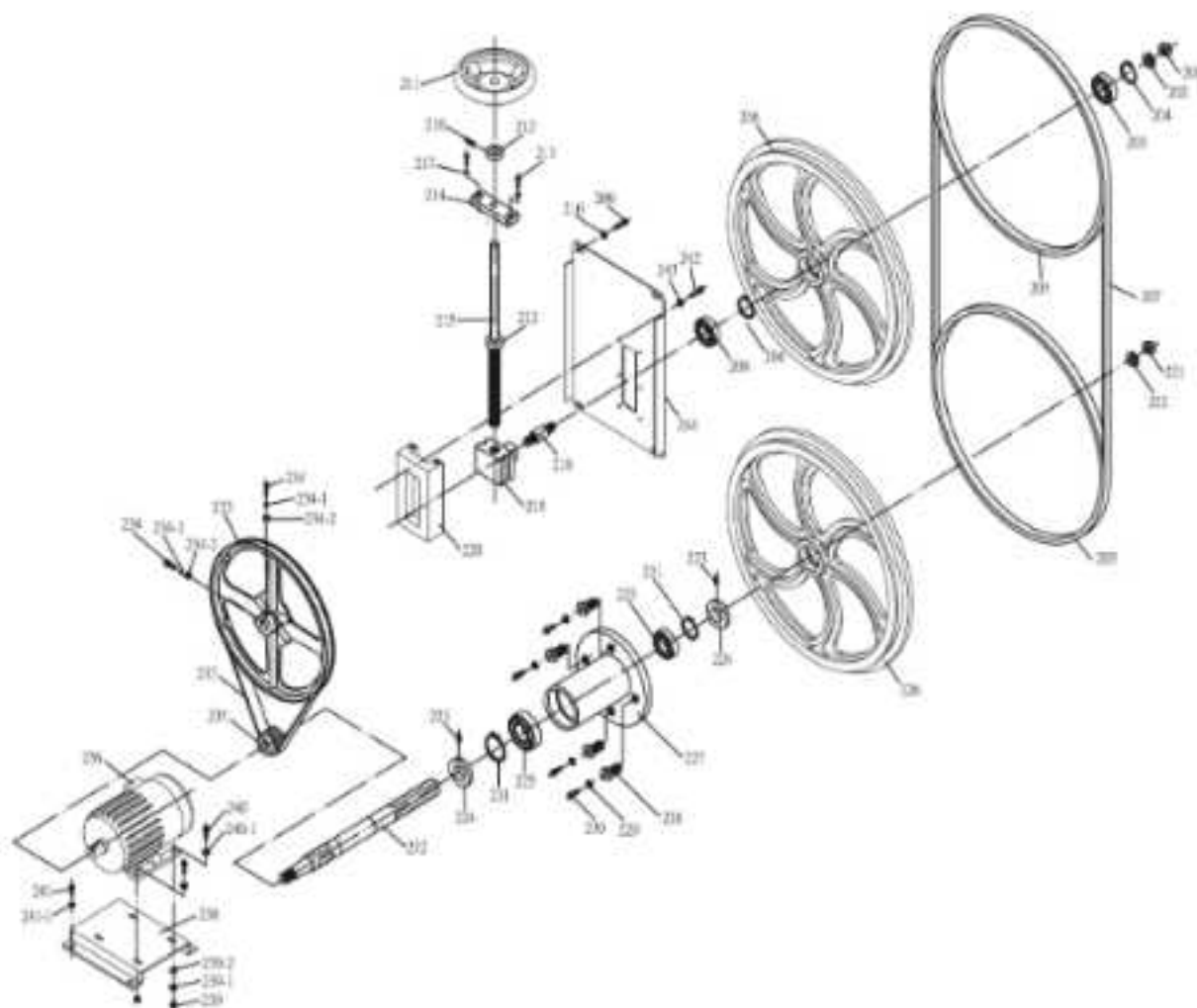

17.1.4 VBS-1207VS-DC Welder Assembly – Exploded View

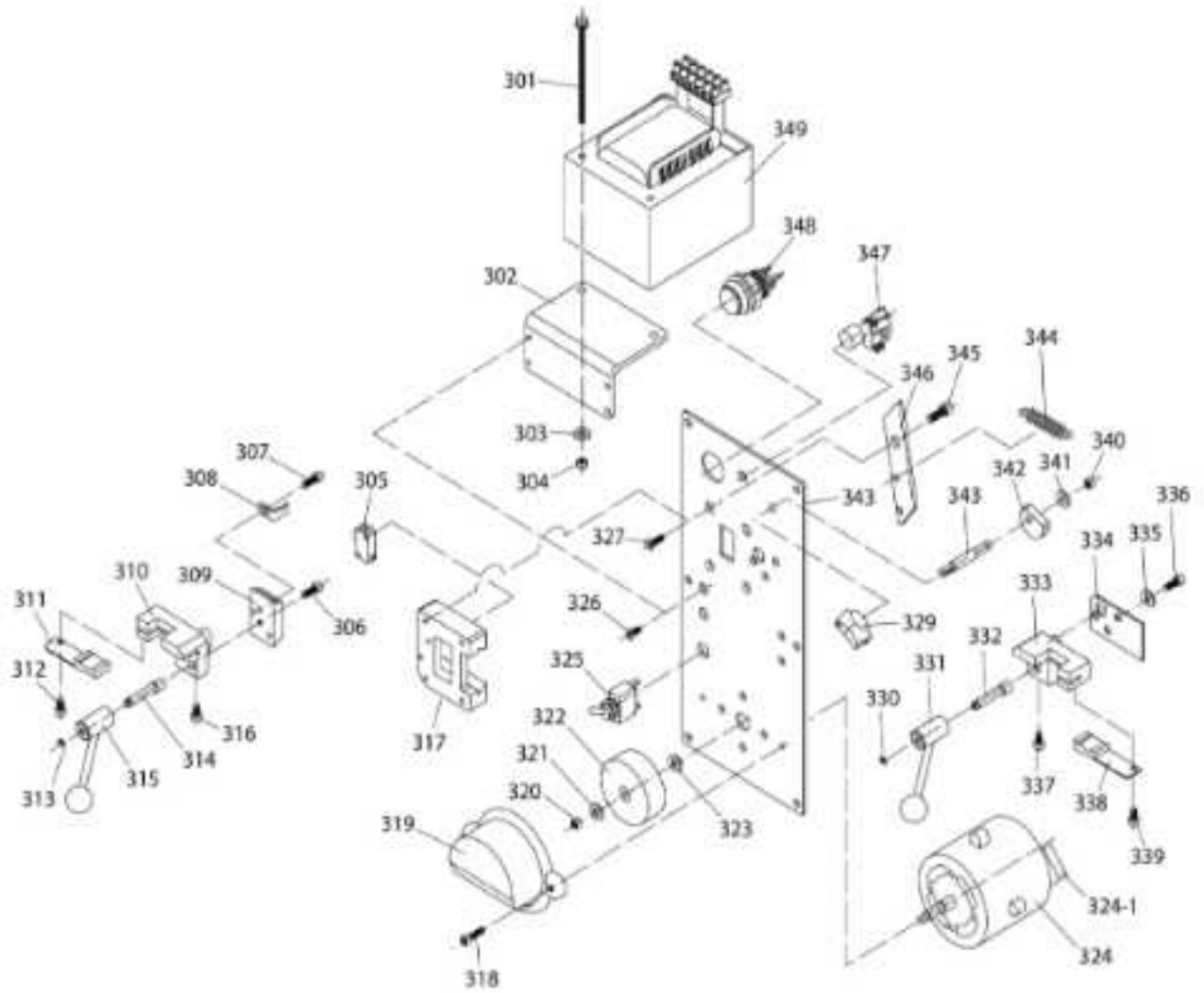

17.2.1 VBS-1207VS-DC Band Saw – Parts List

Index No	Part No	Description	Size	Qty
Cabinet Assembly				
1	VBS1207VS-01	Lower Wheel Door		1
2	BSV12VS-V2-02	Hinge Pin Lower		2
3	VBS1207VS-03	Motor Driver Board	1HP/ 110V	1
3-1	VBS1207VS-3-1	Terminal Block		1
3-2	VBS1207VS-3-2	PU-N/NU Controller	110V	1
3-3	VBS1207VS-3-3	Power Cord	110V/5-15P	1
3-4	VBS1207VS-3-4	DRO Cord		1
3-5	VBS1207VS-3-5	Motor Sensor Cord		1
4	VBS1207VS-4	ON/OFF Switch W/Paddle Complete		1
4-1	TS-1532052	Pan Head Machine Screw	M4x16	2
4-2	TS-1540021	Hex Nut	M4	2
5	BSV12VS-V2-05	Blade Cleaning Brush		1
6	TS-1503061	Socket Head Cap Screw	M6-1 x 25	1
7	VBS1207VS-7	Upper Wheel Door		1
8	BSV12VS-V2-08	Hinge Pin Upper		2
9	VBS1207VS-9	Blade Speed Digital Read Out		1
10	TS-1490021	Hex Cap Screw	M8-1.25 x 16	2
11	VBS1207VS-11	Blade Shear Assembly		1
12	VBS1207VS-12	Knob		1
12-1	VBS1207VS-12-1	Variable Resistance w/ code		1
13	BSV12VS-V2-13	Air Pump		1
14	VBS1207VS-14	Cabinet Body		1
15	BSV12VS-V2-15	Air Hose	4 x 6mm	1
16	BSV12VS-V2-16	Air Nozzle		1
17	BSV12VS-V2-17	Work Lamp (LED)	110V /220V 9W	1
18	VBS1207VS-18	Handle Lever		2
19	TS-1550041	Flat Washer	M6	4
19-1	TS-1503031	Socket Head Cap Screw	M6 x 12	4
20	TS-1502031	Socket Head Cap Screw	M5 x 12	4
21	VBS1207VS-21	Back Cover		1
22	TS-2246102	Socket Head Cap Screw	M6-1 x 10	8
23	TS-1550041	Flat Washer	6mm	8
24	VBS1207VS-24	Lower Blade Guard Set		2
25	TS-2246102	Socket Head Cap Screw	M6-1 x 10	4
26	TS-1550041	Flat Washer	6mm	4
27	VBS1207VS-27	Chip Tray		1
28	VBS1207VS-28	Door Latch		4
28-1	TS-1540021	Hex Nut	M4	8
28-2	TS-1512011	Socket Head Flat Screw	M4 x 10	8
29	VBS1207VS-29	Door Latch Bracket		4
29-1	TS-1540021	Hex Nut	M4 7 x 32	8
29-2	TS-1512011	Socket Head Flat Screw	M4 x 10	8
	VBS1207VS-28A	Door Latch Assembly (included #28, #29)		1
30	VBS1207VS-30	Laser Bracket		1
30-1	TS-1540031	Hex Nut	M5	2
30-2	TS-1520031	Socket Head Cap Screw	M3 x 8	2
30-3	TS-1502031	Socket Head Cap Screw	M5 x 12	2
31	VBS1207VS-31	Blade Break Sensor		1
31-1	TS-1540011	Hex Nut	M3	1
31-2	TS-1520041	Socket Head Cap Screw	M3 x 12	1
31-3	VBS1207VS-31-3	Sensor Bracket		1
31-4	TS-1501021	Socket Head Cap Screw	M4 x 8	2
32	VBS1207VS-32	Laser Guide		1
32-1	VBS1207VS-32-1	Power Supply For Laser		1
	VBS1207VS-32A	Laser Guide Assembly (includes #32, #32-1)		1
33	VBS1207VS-33	Welder Safety Guard	5mm	1
33-1	TS-1532032	Pan Head Machine Screw	M4 x 10	4
33-2	TS-1550021	Flat Washer	M4	4
33-3	TS-1540021	Hex Nut	M4	4

34	VBS1207VS-34	Acrylic Bracket-Left (Small)		1
35	VBS1207VS-35	Acrylic Bracket-Right (Small)		1
35-1	TS-2284082	Pan Head Machine Screw	M4 x 8	2
35-2	TS-1540021	Hex Nut	M4	2
36	VBS1207VS-36	Acrylic Bracket-Right (Large)		1
37	VBS1207VS-37	Acrylic Bracket-Left (Large)		1
37-1	TS-1532042	Pan Head Machine Screw	M4 x 12	4
38	VBS1207VS-38	Break Off Power Limit Switch		2
38-1	TS-2245162	Socket Head Button Screw	M5 x 16	8
39	VBS1207VS-39A	Blade Speed vs Teeth Chart Assembly		1
39-1	VBS1207VS-39-1	Round Head Machine Screw	M5 x 12	1
39-2	TS-2360121	Flat Washer	M12	1
39-3	VBS1207VS-39-3	Special Screw	M5	1
39-4	TS-1550031	Flat Washer	M5	1
39-5	TS-1540081	Hex Nut	M12	1

Guide Post & Work Table Assembly

101	TS-1502051	Socket Hex Cap Screw	M5-8 x 20mm	2
102	TS-1550041	Flat Washer	M6	2
103	BSV12VS-V2-103	Blade Guide		2
104	BSV12VS-V2-104	Blade Guide Bracket- Lower		1
104-1	BSV12VS-V2-104-1	Blade Guide Bracket -Upper		1
105	BSV12VS-V2-105	Guide Post- Lower		1
106	TS-1505031	Socket Head Cap Screw	M6-1 x 16mm	2
107	BSV12VS-V2-107	Blade Suport Rod -Lower		1
107-1	VBS1207VS-107-1	Blade Suport Rod-Upper		1
108	TS-0561071	Hex Nut	5/8"	1
109	TS-1550061	Flat Washer	8mm	1
110	TS-1550061	Flat Washer	8mm	4
110-1	TS-2361081	Spring Washer	M8	4
110-2	TS-2331081	Nut	M8	4
111	TS-1490071	Hex Cap Screw	M8-1.25P x 40mm	4
112	BSV12VS-V2-112	Trunnion Base		1
113	TS-1504051	Socket Head Cap Screw	M8-1.25 x 20	4
114	TS-2311081	Hex Nut	M8	1
115	BSV12VS-V2-115	Trunnion		1
116	BSV12VS-V2-116	Table Tilt Lock	5/8-11 x 2	1
117	BSV12VS-V2-117	Table		1
118	TS-1490021	Hex Cap Screw	M8-1.25 x 16	1
119	TS-1550061	Flat Washer	M8	2
120	BSV12VS-V2-120	Blade Guard		1
121	TS-1490021	Hex Cap Screw	M8-1.25 x 16	2
122	BSV12VS-V2-122	Guide Post Rack		1
123	BSV12VS-V2-123	Roll Pin	4 x 36	1
124	BSV12VS-V2-124	Guide Post Clamp Plate		1
125		Socket Head Cap Screw	M6-1 x 16	2
126	TS-2361061	Lock Washer	6mm	2
127	BSV12VS-V2-127	Bracket		1
128	BSV12VS-V2-128	Handwheel Handle		1
129	VBS1207VS-129	Handwheel		1
130	BB609ZZ	Bearing	609ZZ	1
130-1	STW9BK	C-Ring	STW9BK	1
131	BSV12VS-V2-131	Worm Gear	P6.2832/OD27MM	1
132	BSV12VS-V2-132	Guide Post Bracket		1
133	BSV12VS-V2-133	Guide Post Pinion	Gear 15T OD 2MM	1
134	BSV12VS-V2-134	Special Screw	1/2-12 x 9/16	1
135	BSV12VS-V2-135	Special Flat Washer	13 x 35 x T2	3
136	BSV12VS-V2-136	Lock Knob	7/16-14 x 7/8	1

Drive System Assembly

201	HN1/2	Hex Nut	1/2"-20	1
202	TS-0720111	Lock Washer	1/2"	1
203	BB6203	Ball Bearing	6203ZZ	1
204	BSV12VS-V2-204	Int Retaining Ring	35mm	2
205	BSV12VS-V2-205	Wheel Tire		2
206	BSV12VS-V2-206	Wheel Upper		1
	BSV12VS-206A	Wheel Upper Assembly (includes #205, #206)		1
207	BSV12VS-V2-207	Bandsaw Blade	1/4"W Standard	1
208	BB6203	Ball Bearing	6203ZZ	1
209	TS-1503031	Socket Head Cap Screw	M6-1 x 12	4
210	TS-1550041	Flat Washer	6mm	4
211	VBS1207VS-211	Blade Tensioning Handwheel		1
212	VBS1207VS-212	Bushing		2
213	TS-1503061	Socket Head Cap Screw	M6-1 x 25	2
214	VBS1207VS-214	Leadscrew Bracket		1
215	VBS1207VS-215	Leadscrew	14#	1
	VBS1207VS-215A	Leadscrew Assembly (includes #212, #214, #215)		1
216	TS-1524051	Set Screw	M8-1.25 x 20	1
217	TS-2361061	Lock Washer	6mm	2
218	BSV12VS-V2-218	Upper Wheel Shaft		1
219	BSV12VS-V2-219	Leadscrew Nut	3/4"	1
	VBS1207VS-219A	Leadscrew Nut Assembly (includes #218, #219)		1
220	BSV12VS-V2-220	Tensioning Way		1
221	BSV12VS-V2-221	Ext Nut	5/8"	1
222	TS-0720131	Lock Washer	5/8"	1
223	TS-1524011	Set Screw	M8-1.25 x 8	1
224	BSV12VS-V2-224	Collar		2
225	BB6205	Ball Bearing	6205ZZ	2
226	BSV12VS-V2-226	Lower Wheel		1
	VBS1207VS-226A	Lower Wheel Assembly (includes #205, #226)		1
227	BSV12VS-V2-227	Bearing Housing		1
228	BSV12VS-V2-228	Special Screw		4
229	TS-2361101	Lock Washer	M10	4
230	TS-1505081	Socket Head Cap Screw	M10-1.5 x 50	4
231	BSV12VS-V2-231	Int Retaining Ring		2
232	BSV12VS-V2-232	Lower Wheel Shaft		1
233	BSV12VS-V2-233	Idle Wheel		1
234	TS-1492041	Hex Cap Screw	M12-1.5 x 45mm	2
234-1	TS-2361121	Lock Washer	M12	2
234-2	TS-1540081	Hex Nut	M12	2
235	VBS1207VS-235	Motor Pulley		1
236	VBS1207VS-236	DC Motor	1HP, 10P, 3Ph DC	1
237	BSV12VS-V2-237	V-Belt	A54	2
238	VBS1207VS-238	Motor Base		1
239	TS-1540061	Hex Nut	M8	4
239-1	TS-1550061	Washer	M8	4
239-2	TS-2361081	Lock Washer	M8	4
240	TS-1490031	Hex Cap Screw	M8-1.25 x 20MM	4
240-1	TS-1550061	Washer	M8	4
241	TS-1490031	Hex Cap Screw	M8-1.25P x 20MM	4
241-1	TS-1550061	Washer	M8	4
242	TS-1504051	Socket Head Cap Screw	M8-1.25 x 20MM	6
243	TS-2361081	Lock Washer	8mm	6
244	VBS1207VS-244	Upper Wheel Support Plate		1

Welder Assembly

301	TS-0050171	Hex Cap Screw	1/4"-20 x 4"	1
302	BSV20VS-V2-302	Transformer Bracket		1
303	TS-130005	Flat Washer	1/4"	2
304	TS-0561011	Hex Nut	1/4" x 20	2
305	BSV20VS-V2-305	Limit Switch		1
306	TS-1503061	Socket Head Cap Screw	M6-1 x 25	1
307	TS-1503021	Socket Head Cap Screw	M6-1 x 10	2
308	BSV20VS-V2-308	Limit Switch Bracket		1
309	BSV20VS-V2-309	Sliding Block		1
310	BSV20VS-V2-310	Welding Clamp Left		1
311	BSV20VS-V2-311	Welding Jaw Left		1
312	TS-1503031	Socket Head Cap Screw	M6-1 x 12	1
313	BSV20VS-V2-313	E-Clip	4mm	1
314	BSV20VS-V2-314	Shaft		1
315	BSV20VS-V2-315	Clamp Lever		1
316	TS-1503031	Socket Head Cap Screw	M6-1 x 12	1
317	BSV20VS-V2-317	Sliding Block Base		1
318	TS-1503041	Socket Head Cap Screw	M6-1 x 16	1
319	BSV20VS-V2-318	Grinder Cover		1
320	TS-2311061	Hex Nut	M6	1
321	TS-1550041	Flat Washer	6mm	1
322	BSV20VS-V2-322	Grinding Wheel	DIA 2-1/2"	1
323	TS-1550041	Flat Washer	6mm	1
324	BSV12VS-V2-324	Grinder Motor	1/8HP 110V 1PH	1
324-1	BSV20VS-V2-324-1	Capacitor	3M/250V	1
325	BSV20VS-V2-325	ON/OFF Switch		1
326	TS-1514021	Socket Head Flat Screw	M6-1 x 16	1
327	TS-1514031	Socket Head Flat Screw	M6-1 x 20	1
328	BSV20VS-V2-328	Welding Panel		1
329	BSV20VS-V2-329	Clamp Pressure Knob		1
330	BSV20VS-V2-330	E-Clip	4mm	1
331	BSV20VS-V2-331	Clamp Lever		1
332	BSV20VS-V2-332	Shaft		1
333	BSV20VS-V2-333	Welding Clamp Right		1
334	BSV20VS-V2-334	Insulating Plate		1
335	TS-1550041	Flat Washer	6mm	1
336	TS-1503051	Socket Head Cap Screw	M6-1 x 20	1
337	TS-1503051	Socket Head Cap Screw	M6-1 x 20	1
338	BSV20VS-V2-338	Welding Jaw Right		1
339	TS-1503051	Socket Head Cap Screw	M6-1 x 20	1
340	TS-2311061	Hex Nut	M6	1
341	TS-1550041	Flat Washer	6mm	1
342	BSV20VS-V2-342	Pressure Cam		1
343	BSV20VS-V2-343	Cam Shaft		1
344	BSV20VS-V2-344	Tension Spring	0.8 x 25mm	1
345	TS-0207021	Socket Head Cap Screw	1/4-20 x 1/2	1
346	BSV20VS-V2-346	Bracket		1
347	BSV20VS-V2-347	Annealing Push Button		1
348	BSV20VS-V2-348	Welding Push Button		1
349	BS12VS-V2-349	Transformer	1.2KVA 110V	1
	BS12VS-BWGA-110	Blade Welder With Grinder Assembly	1.2KVA 110V	1

18.0 Electrical Connections

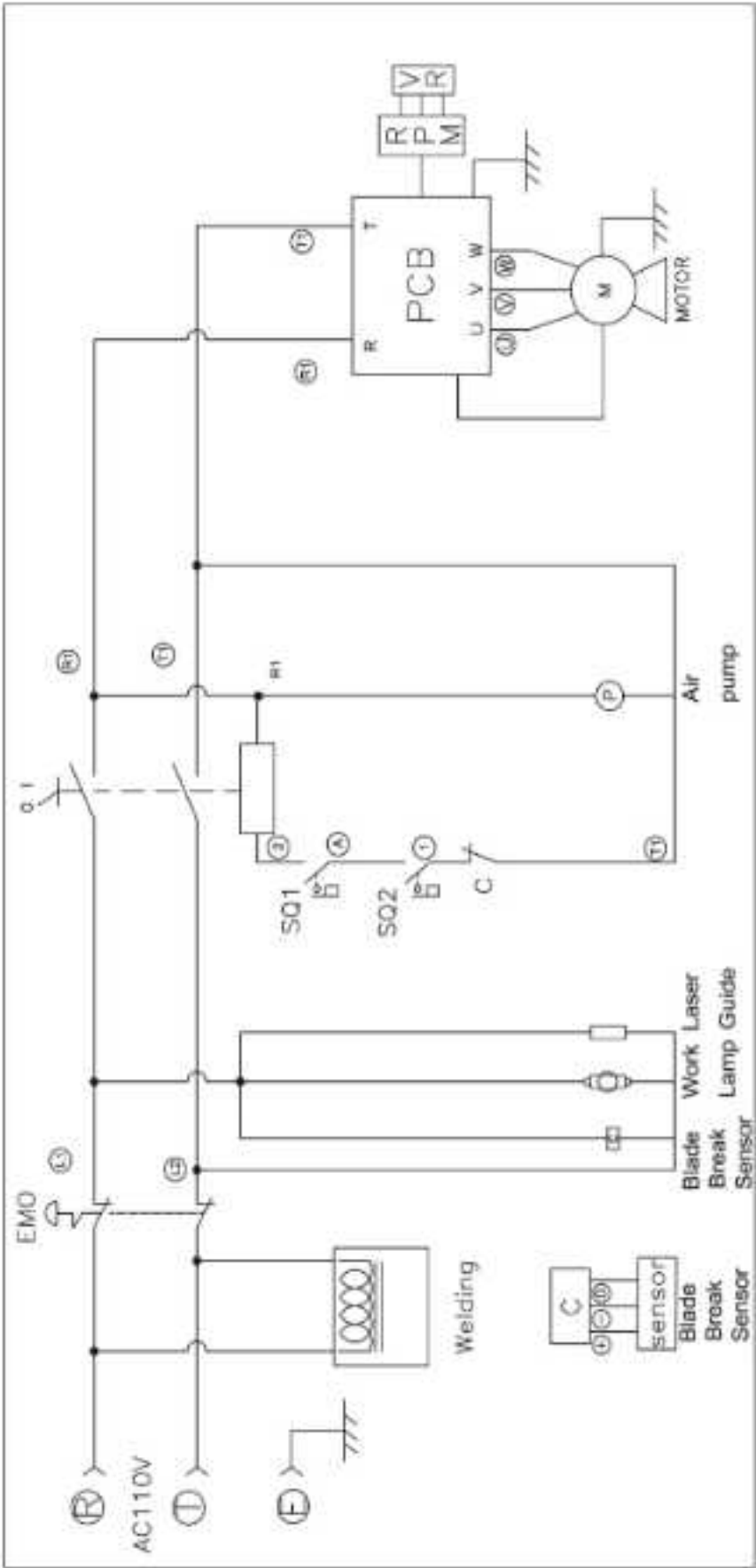

This page intentionally left blank.

This page intentionally left blank.

This page intentionally left blank.

J E T.

427 New Sanford Road
LaVergne, Tennessee 37086
Phone: 800-274-6848
www.jettools.com