

AXIOM

P R E C I S I O N

Operating Instructions and Parts Manual 2x2 CNC Router



JPW Industries d/b/a AXIOM Precision
427 New Sanford Road
La Vergne, TN 37086
Ph.: 844-446-9303
www.axiomprecision.com

Part No. M-AX1-101
Edition 2 07/2025
Copyright ©2025 JPW Industries, Inc.

1.0 Warranty and Service

Limited Warranty Coverage

Each JPW Industries, Inc. (hereafter “Axiom Precision”) CNC machine (“Machine”) and its components (except those listed below under limits and exclusions) is warranted against defects in material and workmanship for a period of 12 months from the date of sale. The foregoing is a limited warranty, and it is the only warranty by manufacturer. Manufacturer disclaims all other warranties, express or implied, including but not limited to all warranties of merchantability and fitness for a particular purpose.

Repair or Replacement only

Manufacturer’s liability under this agreement shall be limited to repairing or replacing, at the discretion of manufacturer, parts or components. Shipment for items replaced under warranty is free, but the shipment method is at the discretion of Axiom Precision. In general delivery for domestic customers will be by UPS ground service or USPS. If overnight or express delivery is requested, additional fees will apply.

Direct phone support is part of the equation that allows us to provide high value at low cost. You must be comfortable with general electrical and mechanical repair concepts, including the appropriate safety procedures, before working on your machine. If you do not have the required skills, you may need to find someone locally to assist you. We do not have factory technicians to send to your facility.

Limits and Exclusions of Warranty

Except as provided above, buyer agrees that all warranties express or implied, as to any matter whatsoever, including but not limited to warranties of merchantability and fitness for a particular purpose are excluded. Components subject to wear during normal use and over time such as paint, labels or decals, finish and condition, seals, bearings, spoil boards, flex cabling, etc., are excluded from this warranty. Axiom-specified maintenance procedures must be adhered to in order to maintain this warranty. This warranty is void if the machine is subjected to mishandling, misuse, neglect, accident, improper installation, improper maintenance, or improper operation or application, or if the machine was improperly repaired or serviced. Warranty of general machine tolerances is void if the machine is disassembled or altered by customer.

Without limiting the generality of any of the exclusions or limitations described in other paragraphs, manufacturer’s warranty does not include any warranty that the machine or components will meet buyer’s production specifications or other requirements or that operation of the machine and/or components will be uninterrupted or error-free. Manufacturer assumes no responsibility with respect to the use of the machine and components by buyer, and manufacturer shall not incur any liability to buyer for any failure in design, production, operation, performance or otherwise of the machine or components other than repair or replacement of same as set forth in the limited warranty above. Manufacturer is not responsible for any damage to parts, machines, business premises or other property of buyer, or for any other incidental or consequential damages that may be caused by a malfunction of the machine or components.

2.0 Table of Contents

Section	Page
1.0 Warranty and Service.....	2
2.0 Table of Contents.....	3
3.0 Safety Information.....	4
Shop Environment.....	4
Health and Safety.....	4
Maintenance.....	5
Operational Practice.....	5
Emergency Switch.....	6
Storage.....	6
4.0 About this Manual.....	7
5.0 Specifications.....	7
6.0 Glossary.....	8
7.0 Assembly.....	10
7.1 Shipping Contents.....	10
7.2 CNC Router Assembly.....	10
8.0 Electrical Connections.....	13
8.1 Grounding Instructions.....	13
8.2 115-Volt Operation.....	13
8.3 Extension Cords.....	13
9.0 Software and CNC Machine Setup.....	14
9.1 Install and Configure UCCNC Software.....	14
9.2 Open UCCNC Software.....	14
9.3 Home Screen Overview.....	15
9.4 Homing.....	16
9.5 Limit Switch Triggered.....	16
10.0 Operation.....	16
10.1 Homing the Machine.....	16
10.2 Installing Cutting Tool.....	16
10.3 Choosing & Affixing Workpiece.....	17
10.4 Set X & Y Origins & Zero X & Y.....	17
10.5 Probe Z Axis.....	17
10.6 Load Toolpath File.....	18
10.7 Start Milling Your Project.....	18
11.0 VCarve Desktop.....	19
11.1 Introduction and Overview.....	19
11.2 Vectric Software Installation.....	19
11.3 Machine Profile and Post Processor.....	19
11.4 Tool Setup.....	19
11.5 Tool Radius Compensation.....	21
11.6 Exporting Created Toolpaths.....	21
12.0 Maintenance.....	22
12.1 General Maintenance.....	22
Performed Daily with Machine Use.....	22
Ball Nut Bearing Service (Every 500 Machine-Hours).....	22
Air Cooling Fan (Every 500 Machine-Hours).....	22
13.0 Troubleshooting.....	23
13.1 Mechanical & Electric Problems.....	23
13.2 Software Errors.....	24
14.0 Replacement Parts.....	24
14.1.1 X-Axis Assembly – Exploded View.....	25
14.1.2 Y-Axis Assembly – Exploded View.....	26
14.1.3 Z-Axis Assembly – Exploded View.....	27
14.1.4 Electric Box Assembly – Exploded View.....	28
14.2 Replacement Parts Lists.....	28
15.0 Electrical Connections.....	30



3.0 Safety Information

The Axiom 2x2 CNC machine is an electrical appliance and precision machine. Protect yourself and your investment. Read and understand the entire owner's manual before attempting assembly or operation. Read and understand the warnings posted on the machine and in this manual. Failure to comply with all the warnings may cause serious personal injury or costly damage to the machine.

This CNC machine is designed and intended for use by properly trained and experienced personnel only. If you are not familiar with the proper and safe operation of a CNC machine, do not use this machine until proper training and knowledge have been obtained.

Your Axiom 2x2 CNC machine is intended for cutting wood, acrylics, wood-fiber composites, certain plastics and non-ferrous metals. Do not use this machine for other than its intended use. If used for other purposes, Axiom disclaims any real or implied warranty and holds itself harmless from any injury, machine damage, or property damage that may result from that use.

Shop Environment

1. Ensure that the floor can bear the weight of the machine and workpieces mounted on it.
2. Keep the floor around the machine clean and free of scrap material, oil, grease, excessive sawdust, excessive wood chips, and debris.
3. Do not lean lumber or other heavy materials against the gantry, guide rails or table.
4. Support the weight of the dust hose attached to the dust shoe accessory to prevent the weight of the hose from dislodging the dust shoe. Ensure that there is sufficient slack in the dust collection hose to allow the spindle to cover the entire work area.
5. Locate the machine away from overhead pipes and plumbing fixtures to prevent condensation from dripping on to the spoil boards and control system components.
6. Locate the machine away from sinks, faucets or other water supplies or storage to prevent splash-out that can damage the spoil boards and control system components.
7. Provide adequate room between this machine and other machines in the shop to reduce the chance of accidental jarring when transporting lumber or other heavy materials through the

shop and while materials are being worked on other machines.

8. Ensure adequate space between machines to allow for the possibility that the workpiece will extend over the end of the CNC table.
9. Store cutting tools in a dry location and prevent contact to preserve the cutting edges.

Health and Safety

1. Always wear approved personal health and safety equipment as indicated for the materials and type of operations that will be performed. These should include a dust mask, hearing protection, safety clothing, and safety glasses/face shield. Do not rely on prescription or over-the-counter eyeglasses; they are *not* safety glasses. Wear ear protectors (plugs or muffs) even during short periods of operation.
2. Before operating this machine, remove any hand, wrist, and neck jewelry and roll sleeves up past the elbows. Confine long hair and do not wear loose clothing which may become caught in the machine. Wear non-slip footwear and use anti-skid floor strips if possible.
3. Use a dust mask or other safeguards to avoid inhaling dust generated from wood products. Install dust collection equipment consistent with shop ventilation practices and budget. Remove dust and debris from the floor frequently to prevent slipping. Drilling, sawing, sanding or milling wood products generates wood dust and other substances known to the State of California to cause cancer. Wood products also emit chemicals known to the State of California to cause birth defects or other reproductive harm. (California Health and Safety Code Section 56).
4. In addition to other health hazards, dust from wood and other materials is flammable. Do not operate welding, wood burning, smelting, soldering or other high-heat tools on the machine's table or vicinity.
5. Do not operate this machine while tired or under the influence of drugs, alcohol or any medication.

	State of California Prop 65 Disclaimer
	WARNING: This product can expose you to chemicals, including dust from wood, wood byproducts, and a variety of plastics, which are known to the state of California to cause cancer.
	For more information, please go to: www.p65warnings.ca.gov

Electrical

1. Make certain the switch is in the OFF position before connecting the machine to the power supply.
2. Make certain the machine is properly grounded and the circuit is protected with a fuse or circuit breaker in accordance with local codes. Install a separate circuit, if necessary, to limit power loss when multiple machines in your shop are operating simultaneously. If necessary, place a cover on the outlet to prevent accidental disconnection.
3. Make all machine adjustments or maintenance with the machine unplugged from the power source.
4. Follow effective lockout procedures to reduce the risk from high voltage wires and components and prevent intentional bypassing of safety controls and accidental operation.
5. Don't use in a damp or wet location.
6. Keep the electrical cord away from sharp edges, heat or moving parts, and do not store materials on top of it. Position the cord so it will not become a tripping hazard.
7. While the use of an extension cord is discouraged, the wiring layout of your shop may not allow machine placement next to an outlet. If an extension cord is needed, make sure the extension cord is in good condition, heavy enough to carry the current requirements, and positioned to prevent a tripping hazard. An undersized cord will cause a reduction in voltage resulting in loss of power and overheating, which may result in fire or electrical shock.

Other Safeguards

1. Do not move the X, Y, or Z-axis by hand when the machine is turned off or unplugged. The movement will spin the axis motor, creating an electrical current that could damage certain electrical components.
2. Remove and store adjusting keys and wrenches before turning on the power. If necessary, for visibility, apply safety markings to adjusting wrenches and keys.
3. Install safety guards consistent with general shop safety practices. Keep safety guards in place at all times when the machine is in use.
4. Check damaged parts immediately. Before further use of the machine, a guard or other part that is damaged should be carefully checked to determine if it will operate properly and perform its intended function.
5. Keep visitors a safe distance from the work area. Keep children away.
6. Control liquids in your shop to limit the possibility of spillage which can damage your

machine and cause personal injury from electric shock or fire. Be careful with storage and use of cleaning fluids, finishes, and solvents. Never use the table to apply or dry finishes.

Maintenance

1. Establish a weekly and monthly maintenance checklist and follow it diligently.
2. Routine maintenance should include periodic checks for alignment of moving parts, looseness or binding of moving parts, worn or bare wires, breakage of parts, skewed mounting and any other conditions that may affect its operation or cause injury. Analyze breakage or damage to determine the cause and take appropriate remedial action.
3. Do not operate this machine if a component of the control system is damaged. It should be properly repaired or replaced before use.
4. Follow instructions for lubricating and changing accessories.
5. Store maintenance tools and supplies nearby, consistent with shop maintenance practices and resources.

Operational Practice

1. Never leave the machine running unattended. Always be in close reach of the emergency stop button.
2. Turn the power off and do not leave the machine until it comes to a complete stop.
3. Avoid pinch points and entanglement hazards. Keep hands and clothing away from the ball screws, thrust bearings, gantry, guide rails and rotating cutting tool while in operation.
4. Use the right tool at the correct speed and feed rate. Do not force a tool or attachment to do a job for which it was not designed. The right tool will do the job better and more safely.
5. Do not touch a cutting tool immediately after use. It will be hot and may cause skin burns. Exercise caution when handling the collet and spindle nut if the cutting tool is hot. Keep a heavy glove or oven mitt on hand for the purpose.
6. Do not lay a hot cutting tool on its side. Create a rack for cooling off hot cutting tools.
7. Use recommended accessories; improper accessories may be hazardous.
8. Do not use dull, gummy, or damaged cutting tools. Keep bits and other cutting tools clean and sharp for best and safest performance.
9. Turn off the machine before cleaning. Use a vacuum, brush or compressed air to remove chips or debris. Do not use hands.
10. Do not climb or stand on the machine. Serious personal injury and costly damage could occur

if the machine tips over or the gantry is dislodged.

11. Remove loose items and unnecessary workpieces from the table before starting the machine.
12. Plan tool paths to make multiple passes rather than to take off a large amount of material at one time. This will reduce mechanical stress and heat on cutting tools.
13. Always secure a workpiece to the spoil board using clamps and/or double-sided tape. If the workpiece is mounted in a fixture, ensure that the fixture is securely held to the table. Never hold a workpiece down by hand while operating the machine.
14. Inspect the workpiece material for any defects that may result in ejection of large pieces of scrap.
15. Make sure the workpiece is free from nails, hardware, or other foreign objects.
16. After installing a cutting tool, make sure the collet is securely tightened. An unsecured cutting tool may fly loose from the collet and cause injury. Be sure that the adjusting wrenches have been removed and are secured before turning on the power.

Emergency Switch

If you need to immediately shut off power to the machine, press the red emergency stop button located on the machine front panel (see Figure 3-1).



Figure 3-1

Storage

If this machine is stored and not used for an extended period (greater than three days), place machine in an atmosphere free from moisture and from excessive changes in temperature. Keep the machine clean and sprayed periodically with silicone spray. Keep the ball screws well-greased.

Familiarize yourself with the following safety notices used in this manual:

⚠ CAUTION

This means that if precautions are not heeded, it may result in minor injury and/or machine damage.

⚠ WARNING

This means that if precautions are not heeded, it may result in serious or fatal injury.

⚠ DANGER

This means that if precautions are not heeded, it will result in serious or fatal injury.

SAVE THESE INSTRUCTIONS

4.0 About this Manual

Axiom Precision provides this manual covering the safe operation and maintenance procedures for this CNC machines. Contained in the manual are installation instructions, safety precautions, operational procedures and maintenance guidelines. The instructions set forth in this document, will ensure this CNC machine provides consistent, long-term operation.

This manual does not cover every facet of machine operation. The use of jigs, fixtures, after-market CNC accessories, choice of materials and tooling may require additional research. Online forums, and CNC blogs are a good source of knowledge from experienced users. Regardless of the methods in place, personal safety is always a priority.

If you have any questions or comments, please call the Axiom Precision Customer Service team at 844-446-9303 or email at axiom-support@jpwindustries.com.

Register your product using the mail-in card provided or register online:

<https://axiomprecision.com/support-us/product-registration>

To quickly reach the product registration webpage, scan the QR code below.



⚠ WARNING

Read and understand the entire contents of this manual before assembly or operation! Failure to comply may cause serious injury!

5.0 Specifications

Model	Axiom 2x2 CNC
Stock Number	AX1-101
Max. Speed	5.08m/min (200ipm)
Step Motor (X/Y/Z)	NEMA 23 Motors 57CM12C-3A-CZ, DC24V, 2PH, 3A, 70W
Spindle Rating	0.8kW 24,000 RPM, Air Cooled
Spindle Voltage	AC 220V
Power Requirements.....	AC 115V, 15A, 50-60Hz, 1Ph
X-Axis Travel.....	24" (610mm)
Y-Axis Travel.....	24" (610mm)
Z-Axis Travel	5.5" (140mm)
Collet	ER11 (1/8" – 1/4")
Running Accuracy	≤0.15mm (0.0059")
Repositioning Accuracy.....	≤0.05mm (0.00196")
Net Weight	165.3 lbs.
Machine Overall Dimensions	31.5" x 36" x 31.5"

The above specifications were current at the time this manual was published, but because of our policy of continuous improvement, AXIOM reserves the right to change specifications at any time and without prior notice, without incurring obligations.

Subject to local/national electric codes.

When running long extension cords, circuit size requirements may differ. Axiom 2x2 is not compatible with standard GFCI outlets. Consult a certified electrician and/or local electric codes for detailed requirements.

6.0 Glossary

Axis – Direction of movement. On a three-axis machine: X (left-right), Y (front-back) & Z (up-down).

Array Work – Division of the machine work surface into square or rectangular workspaces so that the toolpath can be ran in each space to produce several identical profiles.

Ball End (Ball Nose) – A cutting tool that has a rounded cutting arc, where the arc diameter is equal to the cutting diameter.

Ball-screw – Drive system component. The ball-screw is rotated by the stepper motor and provided the means for moving the gantry and spindle along the axes.

Bed – The Bed of the CNC consists of a welded steel frame and an extruded aluminum table top, tongue and groove table top with integrated T-slots.

Breakpoint – The point in a toolpath file where a break is created. In a job file, a breakpoint will allow you to stop work and save a location to resume from later.

Chip Load – Chip load is the measure of the thickness of a chip a cutter will cut.

Climb Cut – Refers to the relationship of the cutting tool rotation to the direction of feed. A climb cut deflects the cutting away from the cut, with the direction of the feed.

Collet – A metal collar that holds the cutting tool within a spindle nut.

Conventional Cut – Refers to the relationship of the cutting tool rotation to the direction of feed. A conventional cut deflects the toward the cut, against the direction of the feed.

Compression Bit – A cutting tool with a combination of up and down shear cutting edges. Typically used for cutting laminate material to prevent tear-out on both sides of the sheet.

Deflection – Tool deflection occurs when the spindle speed and feed rate exert sufficient force to deflect the cutting tool. Deflection leads to excessive wear and chatter which can shorten tool life and will leave unwanted tooling marks on the material.

Down-Shear Bit – A cutting tool whose edges carve downward on the face of the toolpath. Reduces the potential for tear-out but requires a slower feed-rate.

Drag Knife – A cutting tool that holds a razor or knife blade used to cut and inscribe material. Used with spindle or router motors turned off, and freely spins as it follows the direction of the tool-path.

Dust Shoe – An accessory which aids in dust collection by limiting the spread of dust and debris by channeling the air flow through an attached dust collection system.

End-Mill – A cutting tool with a straight end, typically with a spiral flute(s). It creates a channel with a flat bottom perpendicular to the sides.

Feed and Speed – A combination of factors that must be set to control the work performed by the cutting tool.

Feed-rate – The speed at which the cutting tool moves along a workpiece.

Flute Length – The length of the cutting portion on a router bit or cutting tool.

Flutes – The cutting edges or inserts of a router bit or cutting tool.

Finish Cut – A 3D toolpath the reduces or eliminates the irregular contours left by the rough cut.

Form Bit – A bit that carves a standard profile such as a round over, ogee or similar contours.

Gantry – The frame structure that straddles the bed and carries the spindle. It moves on guide rails along the length of the bed and is driven by the ball-screw system.

Gantry Bridge – The part of the gantry that lies between the upright towers. The upper bridge carries the spindle and cooling system. The lower bridge supports the weight of the gantry and affixes directly to the Y axis ball-screw.

Gantry Upright (Towers) – Parts of the gantry that extend upward, supporting the upper gantry bridge.

G-Code – A machine language that uses axis points and commands which the machine uses to move and perform functions.

Grid – The minimal movement units of the router. The router head automatically moves to the next grid position when the directional button is toggled in either continuous or step mode.

Hold-down – A clamp or other such device used to firmly hold a workpiece or fixture to the table. Includes clamps, double-sided tape, vacuum pods and others.

Home Position – Mechanical point set using magnetic limits switches.

Origin – User designated zero point for the workpiece. From which the router will reference the positioning of all cutting.

Plunge – The distance on the Z axis that the spindle and cutting tool moves toward, into, or along the material.

Plunge Rate – The speed of descent of the spindle on the Z axis.

Pocket Tool-path – A toolpath that creates a cavity in the horizontal surface of a workpiece.

Post Processor – A software function that enables the CAD/CAM application to format G-Code enabling the control system of a CNC to follow the designated toolpaths.

Profile Tool-path – A tool paths that cuts along the profile of a set of vectors. Typically used to cut out the shape of a design.

Proximity Switch – A magnetic limit switch that is used to find the HOME position.

Restore Point – The point along a toolpath where the spindle will start to resume a tool-path following a break.

Rough Cut – A 3D toolpath where the initial cut is designed to remove unwanted material, leaving a rough contour.

Soft Limits – Limits on movement availability. Imposed by the workspace boundaries and based on controller settings and the location of HOME. An “out of soft limits error” implies that based on the positioning of the workpiece, there is not enough room to move in a designated direction.

Speed Scale – Allows for the reduction of the feed-rate at the beginning of a toolpath to reduce the stress on a cutting tool as it first contacts the material.

Spindle Speed – Rotational speed of cutting tool (RPM).

Step Down – Distance in Z-axis that the cutting tool plunges into the material.

Step-over – The amount the cutting tool moves away from the previous cutting path as it routes the new path.

Stepper Motor – DC motor that moves in very precise steps upon the receipt of “pulses”, which result in very accurate positioning and speed control.

Surfacing – The process of leveling the surface of the spoil boards so that they are perpendicular to the spindle.

Tool-path – User defined route which the cutter follows to machine a workpiece.

Touch-Off Puck – A device used to set the zero point (Origin) for the Z axis.

U-Disk – External data storage device that is inserted into a USB interface (USB Drive, Flash Disk etc.).

Up-Shear Bit – A cutting tool whose edges carve upward along the face of the toolpath. Increases the potential for tear-out but allows for a slightly higher feed-rate.

VFD – Variable Frequency Drive which controls the speed (RPM) of the spindle. Enables the fine tuning of the spindle during the operation of a toolpath.

Working Envelope – The three-dimensional area that the spindle can travel within while cutting or milling.

7.0 Assembly

⚠ WARNING

Do not connect machine to power source before or during setup and assembly.

Unpack and inspect all parts. Any damage should be reported immediately to your distributor and shipping agent. Do not discard any shipping material until the machine is assembled and running properly. Before proceeding further, read your manual thoroughly to familiarize yourself with proper assembly, maintenance and safety procedures.

Compare the contents of your cartons with the following parts list to make sure all parts are included. Missing parts, if any, should be reported to your distributor.

7.1 Shipping Contents

The items below are shipped with the Axiom 2x2 CNC.

Contents:

- 1 – CNC Router Bed Assembly
- 1 – Z-Axis/Spindle Assembly

Hardware Kit:

- 1 – 12mm Spindle Open Wrench
- 1 – 17mm Spindle Open Wrench
- 1 – Spring Chuck
- 1 – Touch-Off Puck
- 1 – RJ-45 Internet Cable
- 4 – Base Feet with Leveling Nuts
- 4 – M5 x 20 Socket Head Cap Screws
- 1 – Power Cord
- 1 – USB Drive

7.2 CNC Router Assembly



Figure 7-1

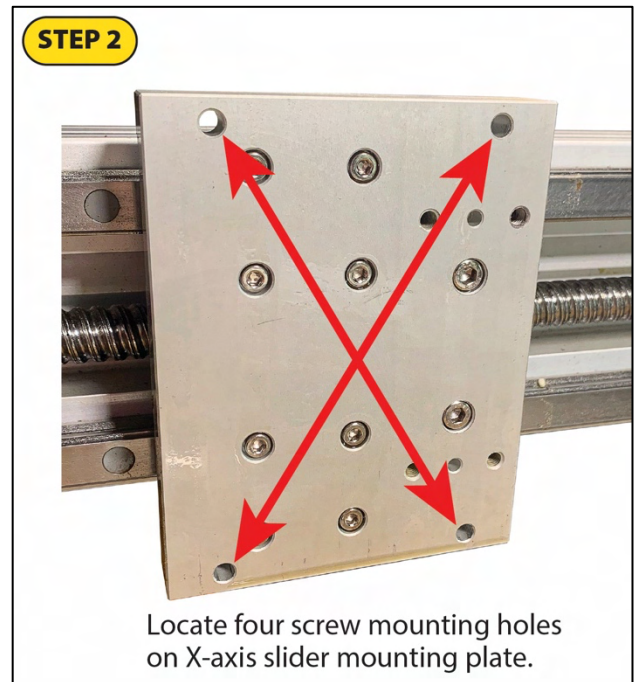

Figure 7-2

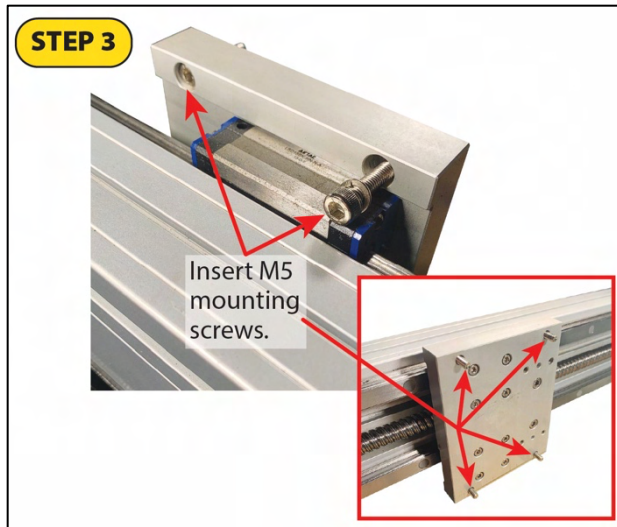

Figure 7-3

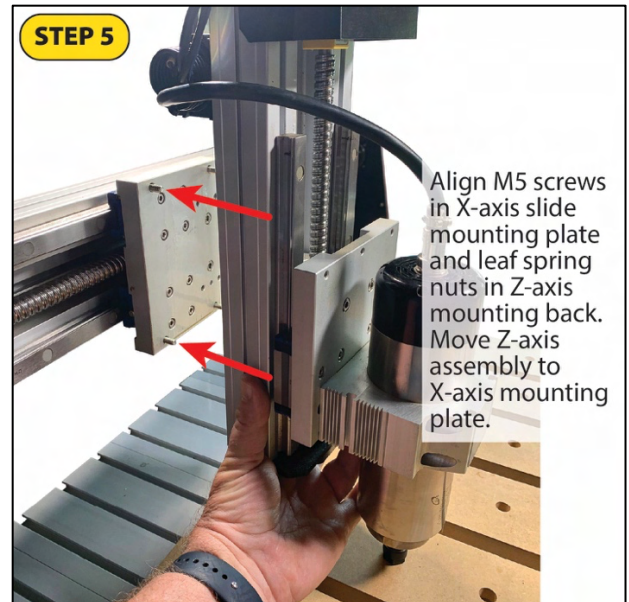

Figure 7-5



Figure 7-4

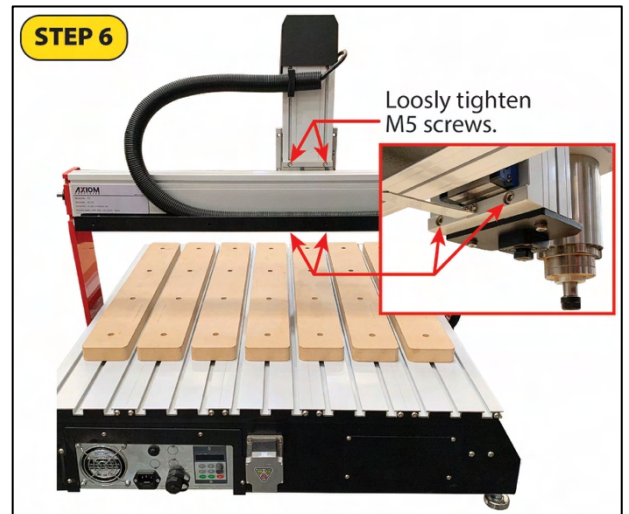

Figure 7-6

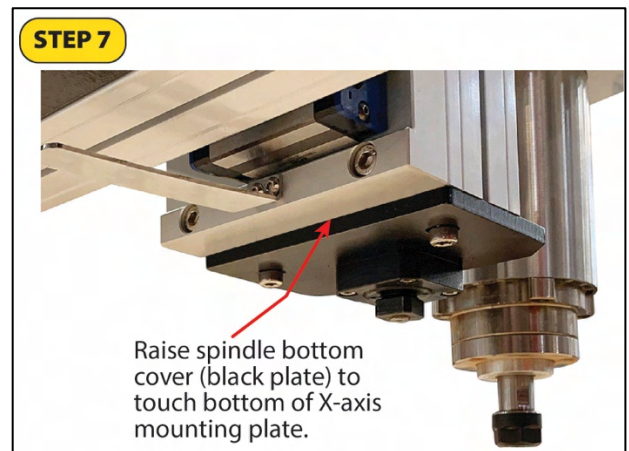

Figure 7-7

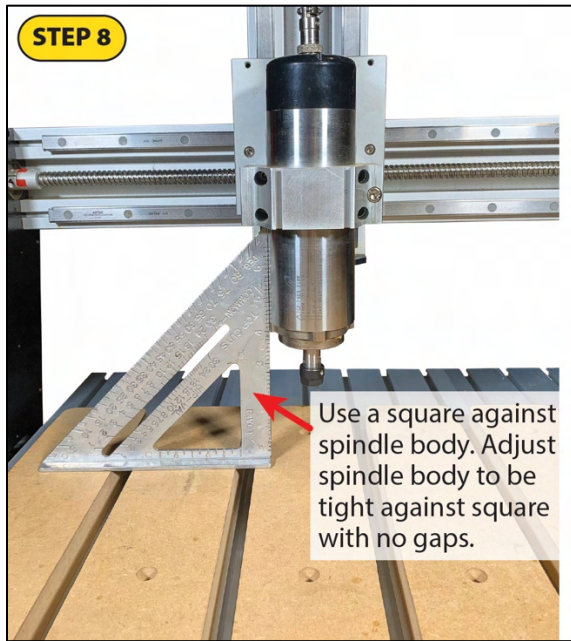

Figure 7-8

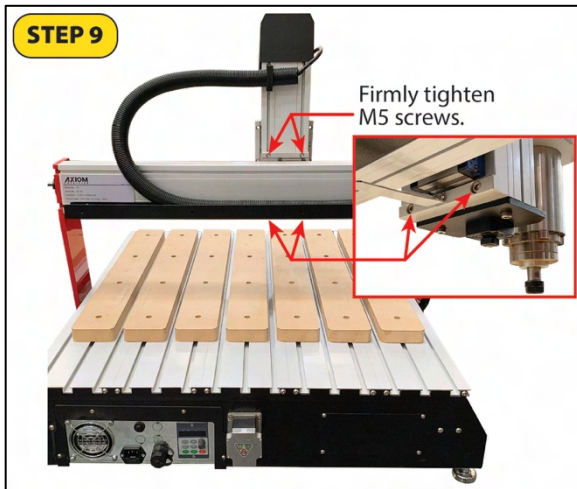

Figure 7-9



Figure 7-10



Figure 7-11

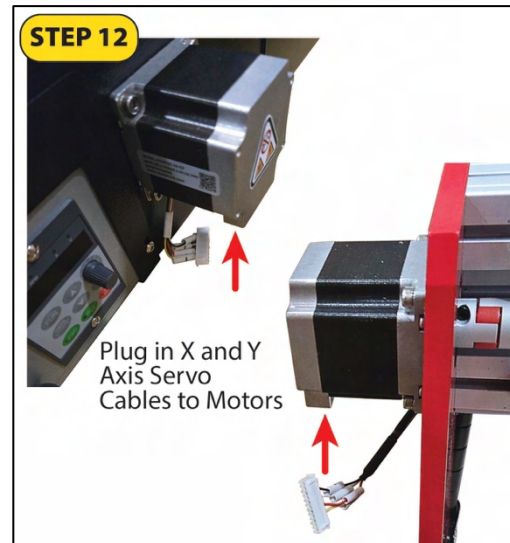

Figure 7-12

8.0 Electrical Connections

⚠ WARNING

Electrical connections must be made by a qualified electrician in compliance with all relevant codes. This machine must be properly grounded to help prevent electrical shock and possible fatal injury.

NOTE: When running long extension cords, circuit size requirements may differ. This machine is not compatible with standard GFCI outlets. Consult a certified electrician and/or local electric codes for detailed requirements.

Before connecting to power source, be sure ON/OFF switch is in the OFF position.

The power supply should be a dedicated 15-amp circuit with a 15-amp circuit breaker or time-delay fuse marked "D". **Local codes take precedence over recommendations.**

8.1 Grounding Instructions

This machine must be grounded. In the event of a malfunction or breakdown, grounding provides a path of least resistance for electric current to reduce the risk of electric shock. This machine has a three-wire electric cord that includes a grounding plug. The plug must be plugged into a matching outlet that is properly installed and grounded in accordance with all local codes and ordinances.

Do not modify the plug provided - if it will not fit the outlet, have the proper outlet installed by a qualified electrician.

Improper connection of the equipment-grounding conductor can result in a risk of electric shock. The conductor with insulation that is green, with or without yellow stripes, is the equipment-grounding conductor. If repair or replacement of the electric cord or plug is necessary, do not connect the equipment-grounding conductor to a live terminal.

⚠ WARNING

Check with a qualified electrician or service person if the grounding instructions are not completely understood, or if in doubt as to whether the machine is properly grounded. Failure to comply may cause serious or fatal injury.

8.2 115-Volt Operation

Referring to Figure 8-1:

This model is intended for use on a 115V circuit and has a grounded outlet that matches the machine's electrical cord plug, as shown in Figure 8-1.

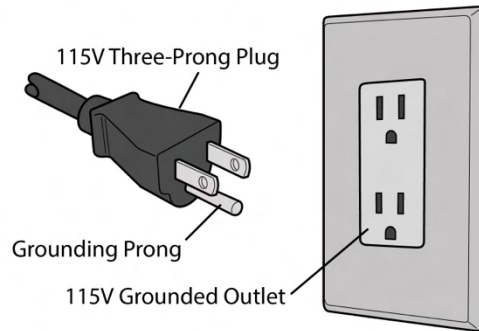

Figure 8-1: 115V Connection

If the outlet is not a properly grounded three-pole receptacle, do not use a temporary adaptor. Have a properly grounded three-pole receptacle installed by a qualified electrician.

8.3 Extension Cords

The use of extension cords is discouraged. If possible, position your machine within reach of the power supply. If an extension cord becomes necessary, use only 3-wire extension cords that have 3-prong grounding plugs and 3-pole receptacles that accept the tool's plug. Make sure the cord rating is suitable for the amperage listed on the machine's motor plate. An undersized cord will cause a drop in line voltage resulting in loss of power and overheating.

Do not use a damaged or worn extension cord. Repair or replace before use.

Use Table 1 as a general guide in choosing the correct size cord. If in doubt, use the next heavier gauge. The smaller the gauge number, the heavier the cord.

Recommended Gauges (AWG) of Extension Cords

Amp Rating		Volts	Total length of cord in feet			
More Than	Not More Than	120	25	50	100	150
		240	50	100	200	300
		AWG				
0	6		18	16	16	14
6	10		18	16	14	12
10	12		16	16	14	12
12	16		14	12	Not Recommended	

Table 1

9.0 Software and CNC Machine Setup

You are now ready to install software, configure your computer, make computer and electrical connections, and make software and hardware adjustments prior to milling your first project.

In this section, you will:

- Install and configure UCCNC software on your Windows® computer.
- Learn more about the software home screen functions.
- Home the machine.
- Learn what to do if a limit switch is triggered.

9.1 Install and Configure UCCNC Software

For detailed information on how to install the UCCNC software, refer to the software installation instruction video found on the USB drive included with this machine. The USB drive also contains the UCCNC software and the UCCNC profile and license files needed to complete the installation.

You can also access the instruction video and software download link by scanning the QR code below. You will still need the license file located on the USB drive.

If you need further help installing the software, call the Axiom Precision Customer Service team at 844-446-9303.



9.2 Open UCCNC Software

1. Go to your PC desktop and open the AXIOM-2x2 profile shortcut located on your PC desktop (see Figure 9-1). You will see a loading screen with a progress bar (see Figure 9-2).

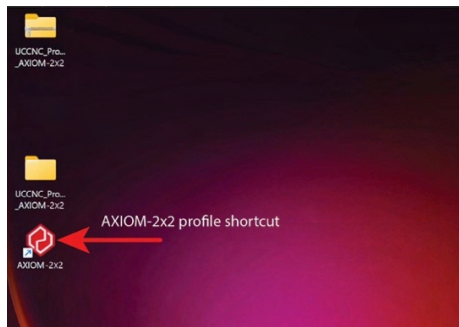

Figure 9-1



Figure 9-2

2. If you see a screen asking you to select the motion controller (shown in Figure 9-3), either you opened the software before the PC / CNC machine connection was established or something is blocking the PC/CNC machine connection. Close the UCCNC application, wait a few seconds, and reopen the application. If the screen appears again close the UCCNC application and turn the CNC machine off for five seconds. Power the machine back on and wait 20 seconds for the PC/CNC connection to be established. Open the UCCNC software again.

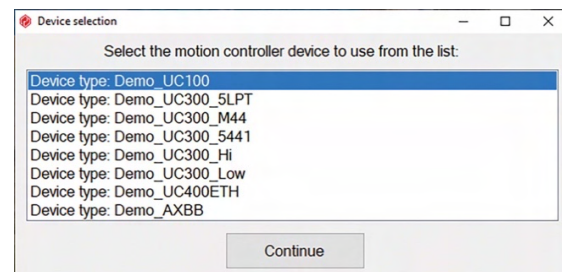

Figure 9-3

3. When the UCCNC application loads up, you should see a home screen as shown in Figure 9-4.
4. In the lower right corner of the home screen, the "RESET" button will be flashing. Click on this button to disable the initial alarm. If it will not reset, either the E-stop is activated or an axis movement limit switch is not being activated. First check the E-stop button and see if it has been pressed. If so, rotate the E-stop button clockwise to release. If the "RESET" button still doesn't reset when clicked, check the axis movement limit switches. If the machine is resting on one of the limit switches, the RESET button will not reset. See section 9.5 *Limit Switch Triggered* to clear this problem.

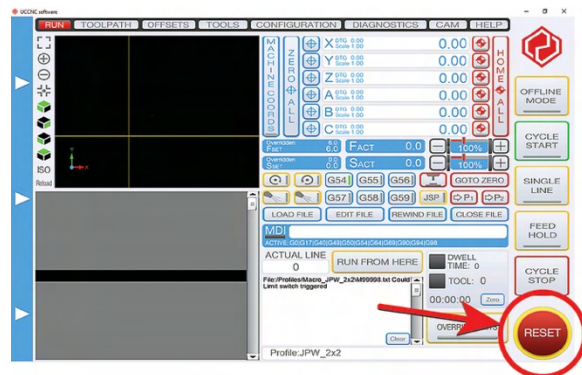

Figure 9-4

9.3 Home Screen Overview

The left side of the home screen contains a blue bar with three arrows pointing right. Hovering on this bar expands the axis jogging controls panel.

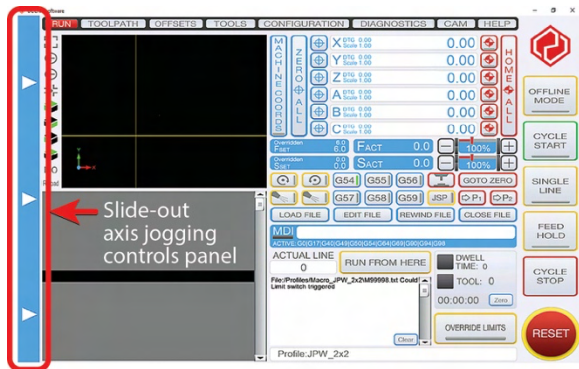

Figure 9-5

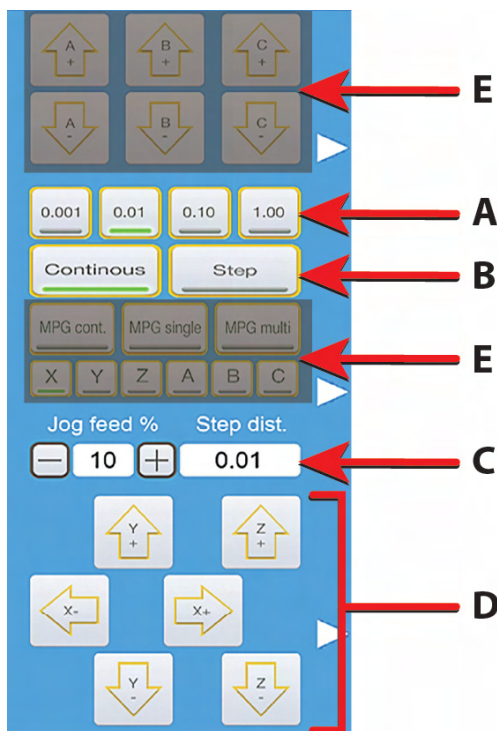

Figure 9-6

Axis Jogging Control Panel (Figure 9-6):

- A. Single step movement increments
- B. Continuous or single step movement
- C. Set jog feed speed for manual movement
- D. X, Y, & Z axis movement buttons
- E. Controls not applicable to this machine

You can also manually move the axis positions using your PC's keyboard. See Figure 9-7. Hold the Shift for rapid move.

PC Keyboard Z-Axis

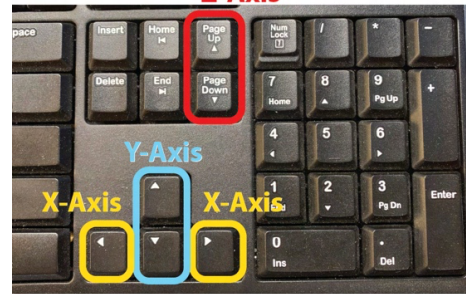

Laptop Keyboard

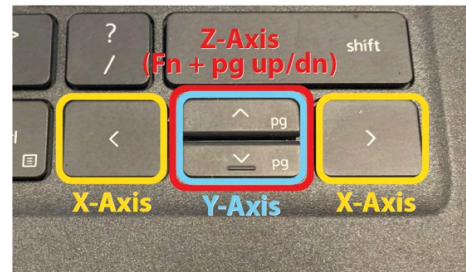

Figure 9-7

Current Position Display (Figure 9-8):

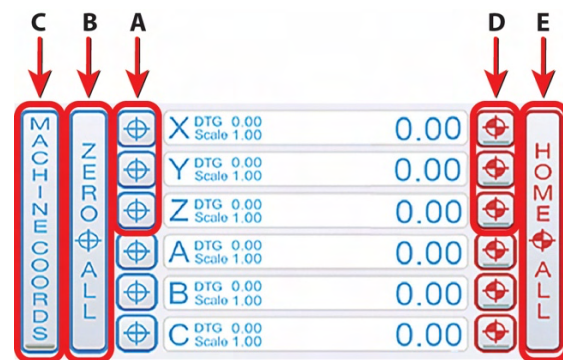

Figure 9-8

- A. Set project zero point for each axis.
- B. Set project zero point for all axis.
- C. Switch the position display to machine coordinates. The red indicator mark at the bottom is visible when this option is activated.
- D. Drive to the set zero point for the project.
- E. Home all axis.

File Management (Figure 9-9):

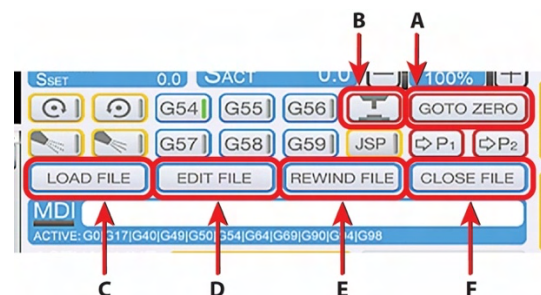

Figure 9-9

- A. Moves to set zero point.
- B. Probe Button for setting Z axis zero point

- C. Load CNC file. Acceptable file types are .txt, .ngc, .nc, and .gcode.
- D. Edit the loaded file in a text editor.
- E. Rewind file to chosen position.
- F. Close currently loaded file.

Project Display (Figure 9-10):

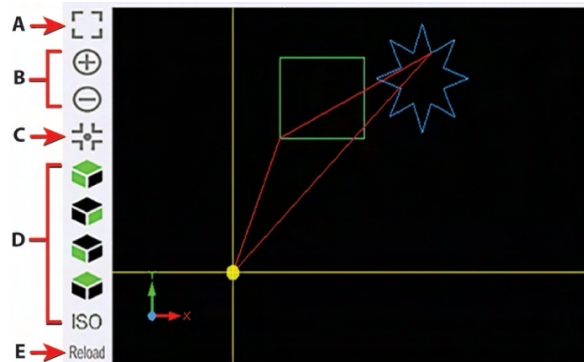

Figure 9-10

- A. Reset the display.
- B. Zoom in and out of display image.
- C. Center crosshairs on display.
- D. Select different views of loaded file.
- E. Reload the display image for the current file.

The yellow crosshairs show the current location of the tool. The green lines show paths that have been completed. The blue lines show paths that are yet to be completed. The red lines show the jog routes.

9.4 Homing

Before jogging the machine or loading a toolpath, the machine must be homed. Homing the machine locates all three axis to their reference point and tells the software where the edges of the machine movement are. You must do this each time the machine is turned on. You must also do this after the E-stop button has been activated.

To home the machine, press the HOME ALL button (see Figure 9-11).



Figure 9-11

The axis moves slowly while homing. To speed the process, manually move the axis closer to the home position and press the HOME ALL button.

9.5 Limit Switch Triggered

At times, when jogging the machine to the end of the machine travel, a limit switch might be triggered. When this happens, the software will prevent you from controlling the machine. You will not be able to reset the software when the limit is triggered. When this happens, press the “OVERRIDE LIMITS” button and then press the “RESET” button to regain control of the machine. Make sure you jog the spindle away from the limit switch. You are now back in the zone of machine operation.

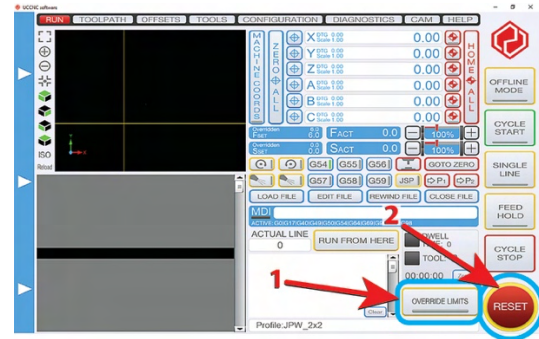

Figure 9-12

10.0 Operation

10.1 Homing the Machine

Each time the machine is turned on and before loading a toolpath file, you must home the machine. Follow the information in section 9.4 Homing.

10.2 Installing Cutting Tool

WARNING

Before installing or changing the cutting tool in the router spindle, you must deactivate the spindle system to prevent accidental spindle startup. Follow the steps below to safely handle the router spindle.

The machine spindle can receive 1/8” and 1/4” CNC router bits. Make sure the bit is sharp and is not damaged.

To install CNC router bit:

1. Open the UCCNC software.
2. When the software opens, the “RESET” button will be flashing. This shows that the reset button is engaged, and the machine cannot operate. If the software was already open and you need to change the router bit, press the “RESET” button to make it flash.

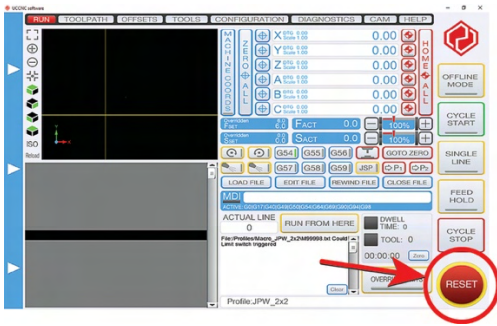

Figure 10-1

- Loosen the spindle nut and insert the desired bit into the nut/collet assembly.



Figure 10-2

- Tighten the spindle nut with the two supplied wrenches.



Figure 10-3

10.3 Choosing & Affixing Workpiece

Choose the appropriate workpiece. Make sure the workpiece material is appropriate for use with this machine.

Choose an appropriate spoil board to place beneath the workpiece. The spoil board will protect the machine's MDF surface strips.

Your Axiom 2x2 CNC machine is intended for cutting wood, acrylics, wood-fiber composites, certain plastics and non-ferrous metals.

⚠ WARNING

Never hold a workpiece down by hand while operating the machine.

- Place your spoil board and workpiece on the desired area of the worktable. Affix the spoil board and workpiece using your desired method. You can use clamps, double-sided tape, double-sided adhesive sheets, toolmakers vice, etc.

⚠ CAUTION

If using clamps, vices, or other type of holding tools, be sure they will not be contacted by the CNC router cutting tool.

10.4 Set X & Y Origins & Zero X & Y

- Jog the X, Y, and Z axis by one of the methods described in section 9.3 *Home Screen Overview*. Move the X, Y, and Z axis over your workpiece to the datum position that you set up in the CAD/CAM software (left front, left rear, right front, or right rear).
- After reaching this position, zero the X & Y axis to establish the work origin for your toolpath. Do this by pressing the "Zero X" and "Zero Y" buttons.

10.5 Probe Z Axis

To set your Z axis zero point, you will use the probe and the touch off puck (provided).

- Plug the included touch off puck into the port on the left side of the Z axis cover (see Figure 10-4).

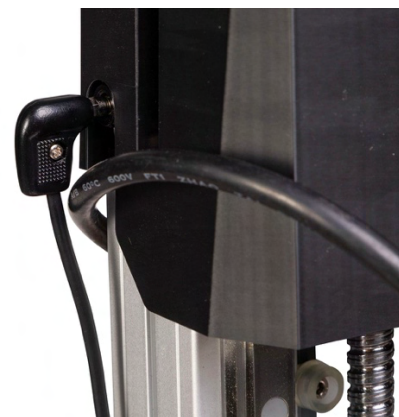

Figure 10-4

- Place the touch off puck on top of your workpiece and under the installed bit (see Figure 10-5).

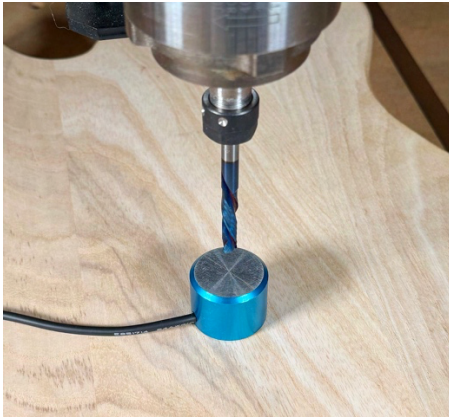

Figure 10-5

3. Press the “Probe Button” on the UCCNC home screen (see Figure 10-6). The bit will lower until it touches the puck and then it will move back up. The software sets the zero point automatically.

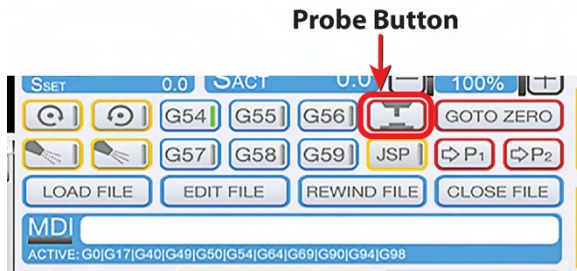

Figure 10-6

10.6 Load Toolpath File

You are now ready to load a toolpath. The toolpath can be created using the supplied VCarve Desktop software or another CAD/CAM software of your choice. For VCarve Desktop instructions, see section 11.0 *VCarve Desktop*.

If using software other than VCarve Desktop, you will need to install a post processor for UCCNC to output correct formatting of the G-Code files. The toolpath will create a .txt file.

1. To load your desired toolpath, press the “LOAD FILE” button (see Figure 10-7). Your PC will open a navigation window allowing you to locate the toolpath file.

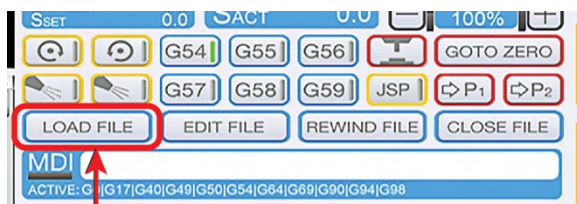

Load File Button

Figure 10-7

2. Double-click the file or click once to highlight the file and then click the “Open” button. The UCCNC software will load your toolpath. When

the file is loaded, you will see a preview in the project display (see Figure 10-8).

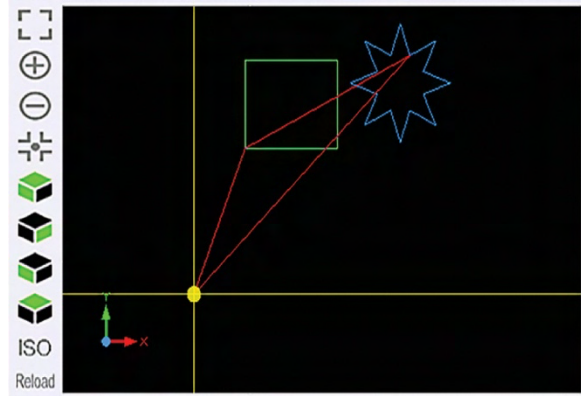

Figure 10-8

10.7 Start Milling Your Project

Once the toolpath is loaded, you can start the milling process.

1. Press the “CYCLE START” button to begin milling your project.
2. Once the program is complete, the spindle will stop and the machine will move to the park position.

Stopping Before Milling Cycle Finishes:

If there is an emergency, the program can be stopped by pressing the “CYCLE STOP” button or the “RESET” button on the software home screen, or by pressing the E-stop button on the front base of the machine.

NOTE: After an emergency stop or a cycle stop, look at the “ACTUAL LINE” window on the software home screen and note where in the toolpath the machine was stopped. You can restart from this position or back up a few lines of the G-code and restart using this recorded line once the emergency is cleared.

To Restart Your Project:

1. Home your machine before restarting. See section 9.4 *Homing*.
2. Press the “REWIND FILE” button and enter the noted stopped position in the “ACTUAL LINE” window. Click the “RUN FROM HERE” button to set the start point.
3. When ready to resume the milling project, press the “CYCLE START” button. Confirm the information in the pop-up window. The spindle will move to the restart position.
4. Once the restart position is met, press the “CYCLE START” button again to start the milling process.
5. Once the program is complete, the spindle will stop and the machine will move to the park position.

11.0 VCarve Desktop

11.1 Introduction and Overview

VCarve Desktop is the most basic software available from Vectric. It's a very popular CAM package and is easy to use.

The best way to learn how to use VCarve Desktop is to use it. For additional help, visit <https://www.vectric.com/products/vcarve/> for more information on how to install and use the included VCarve software.

VCarve Desktop provides a preview of your part with machine toolpath overlaid. This allows you to see what your part will look like and to check for mistakes.

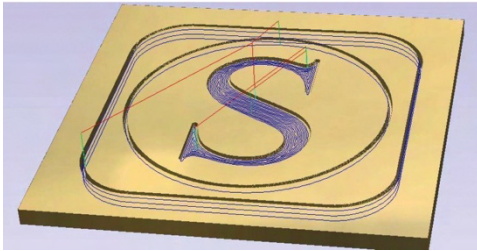

Figure 11-1

11.2 Vectric Software Installation

Included with this machine is the software and the license number specific to your machine.

11.3 Machine Profile and Post Processor

VCarve Desktop requires a post processor file to export your created toolpaths into a file that is usable by your machine. It is recommended to setup a machine profile for your machine inside the VCarve Desktop software. This can be done through the Machine tab. Select Add Machine from the Machine tab drop down (see Figure 11-2). Add machine details as shown in Figure 11-3. Once entered, locate and click the "+" icon to the right of "Associated Post-Processors." For the Axiom 2x2 machine, you must select the "Mach2/3 ATC Arcs (mm)(*.txt)" post processor as shown in Figure 11-4. The drop down menu in VCarve Desktop has many post processor options. Make sure to choose the "Mach2/3 ATC Arcs (mm)(*.txt)" to generate toolpaths compatible with the Axiom 2x2 machine. Click the "Apply Button" to save the profile and the "OK" button to exit.

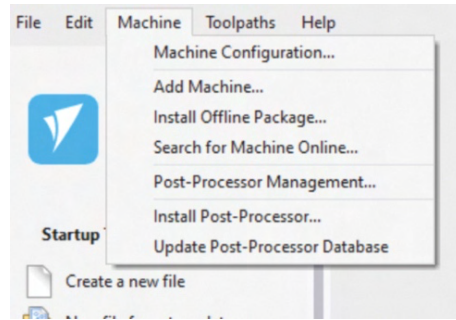

Figure 11-2

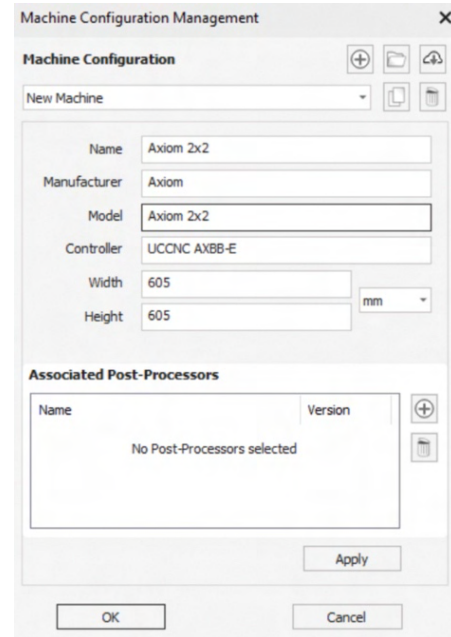

Figure 11-3

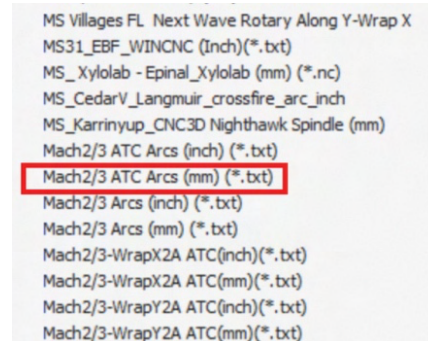

Figure 11-4

11.4 Tool Setup

See below for the tool window that opens when you select the tool to use in VCarve Desktop.

VCarve Desktop allows you to build up a tool database so you can setup a tool for each material/cutter combination. You can save tools for various jobs. As you learn, you will find some settings work better than others. When you find the sweet spot, you can save the settings in the tool library. To help you with your settings they are explained as follows:

- Name – Naming the tool is not important for the settings, but its good practice to be descriptive of what is in the settings.

- Tool Type – This is important as it tells VCarve what sort of tool you are using. This will affect the calculations and the live demo. Always choose the same tool as you are using

- Notes – This field is useful for documenting specific outcomes or requirements needed when running with specific tools and settings. For example: “Make sure to clamp workpiece well when running with these settings”.

- Diameter – The diameter of the tool tells VCarve Desktop how to approach tool radius compensation. If for example: You set the tool diameter to 4mm, VCarve Desktop will then make the toolpath run 2mm outside the path you specify (if compensating for tool radius on the outside) to account for the tool geometry.

- Pass Depth – This is the maximum depth that a tool can go each pass. For example: If your cut depth is set at 5mm, and you are using a 1mm cutter, a good strategy would be to machine the 5mm in 1mm passes. VCarve Desktop will then program the machine to cut down 1mm at a time down to the 5mm cut depth.

- Step Over – The step over controls how much overlap there is between passes as the cutter clears the pocket.

- Spindle Speed – This allows you to set the spindle speed for the file you are creating. The spindle operates between 0 and 24,000 RPM. Lower RPM settings will affect the spindle torque output.

- Feed Rate – This parameter is the speed of the machine when milling the work in the X and Y directions. The machine can rapidly move at up to 5000mm/min. Typically, milling speeds are at 700 to 2000mm/min. Stick to 1500 with a pass depth of 0.5mm or 1mm when you get started. You can build confidence and speed as you get used to using the machine. If your machine is too fast, the machine will stall, and you will lose position. Be careful and be conservative when learning to use this machine.

- Plunge Rate – This is the same as the feed rate except it related to the Z direction. Typically, milling cutters (like slot drills etc.) prefer to mill in X and Y and are not as efficient in the Z / plunge direction. Keep this setting at 500mm/min as you get started.

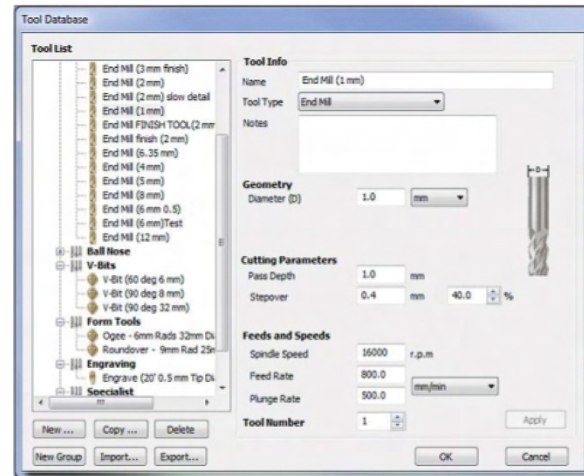

Figure 11-5

NOTE: It is very important that you choose and use the same scale in either inches/min or mm/min (see Figure 11-6).

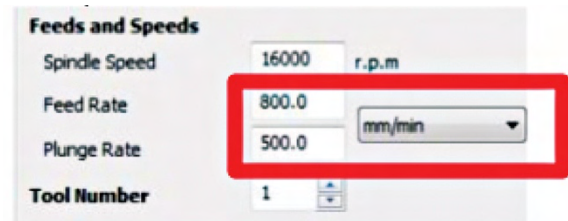

Figure 11-6

Zeroing The job setup is important. You can see the faint cross hairs on the workpiece drawing. The cross hairs appear in the center of the work. This is because the X, Y origin is setup in the center of the job setup on the left hand side. You can also setup the job origin to be the bottom left. It is very important that you are consistent with the setup in VCarve Desktop and with the machine. We recommend using the middle of your workpiece. If you zero in the middle in VCarve Desktop (as shown in Figure 11-7), you need to zero the machine in the middle of the workpiece.

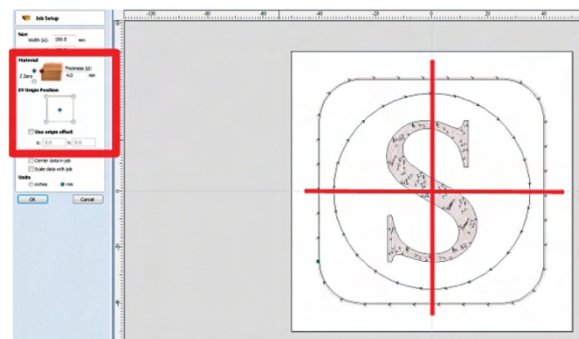

Figure 11-7

As we have set the thickness of the work to be 4mm (as per our plywood), and we set the cut depth of the final outline cut to be 4.5mm, VCarve Desktop will give a warning. You can still proceed, its simply telling you that you are going to machine deeper than your materials thickness.

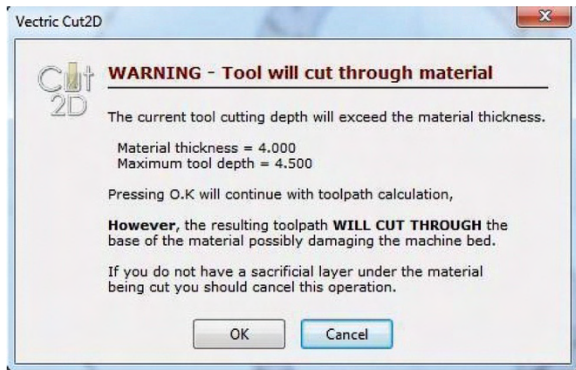

Figure 11-8

If you have a spoil board under your workpiece (which you do with the MDF), then cutting through deeper than the material thickness will ensure you cut all the way through and around the entire perimeter and leave minimal finishing

11.5 Tool Radius Compensation

For VCarve to carry out effective tool radius compensation (accounting for the fact that the tool has a diameter) Make sure that when you select your tool:

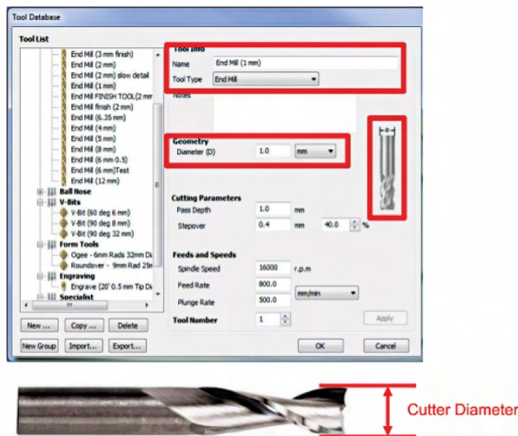

Figure 11-9

- You select the correct tool type – in this case an end mill. You will see an image of a tool sample on the right hand side in the above figure.
- You enter in the correct tool diameter. The tool diameter is the diameter of the “hole” or the width of the “channel” the tool will make in the workpiece. One way to measure this (if not written on tool) is to slowly plunge the tool into a sample workpiece – say MDF or plywood (jog only in Z and make sure the spindle is on). The circular hole the milling cutter makes in the workpiece (ply or MDF) is the cutter diameter. You can now measure this with a ruler or caliper. NOTE: It is best to specify the cutter diameter from the supplied cutter specifications.
- Take some notes for specific jobs. You might find optimal settings for a specific material. It is a good idea to create a new tool with this material selected in your tool library. This will give a reference for the next time you need this cut on this material.

11.6 Exporting Created Toolpaths

Once you have finished creating your toolpaths and are ready to take them to your machine, you will need to export them. From the Toolpath Operations Menu, select the tool & floppy disk icon (see Figure 11-10). For now, select "Visible toolpaths to multiple files", as shown in Figure 11-11. NOTE: Selecting "Group where possible" will combine toolpaths that have the same tool selected. Be sure that these toolpaths are OK to run in sequence before selecting.

“Axiom 2x2” and “Mach2/3 Arcs (mm)(* .txt)” should be populated in the Machine and Post Processor fields (see Figure 11-11). If not, select them. You can then click “Save Toolpath(s)” to export and save to your desired location.

Tip: It's helpful to include a number to the start of toolpath names. This helps in saving and selecting the files in the order you would like to run them.

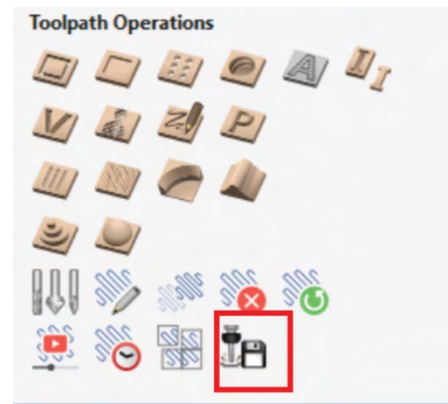

Figure 11-10

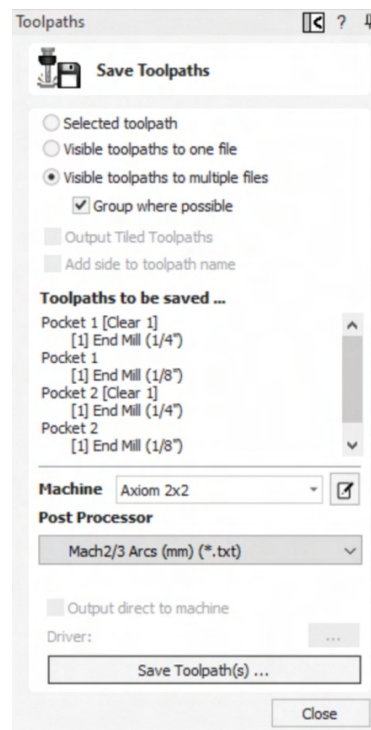

Figure 11-11

12.0 Maintenance

WARNING

Disconnect machine from power source before doing any maintenance. Failure to comply may cause serious injury.

12.1 General Maintenance

Performed Daily with Machine Use

1. Keep machine clean and free from dirt, dust, and debris.
2. Regularly clean the prismatic guides and roller ball-screws on all axis. Wipe them down with a light machine oil, such as 3-IN-ONE multipurpose oil. Move the machine through travel limits to properly disperse oil.
3. Check cutting tool edges for chips and/or dullness.
4. Inspect the machine for damage.
5. Inspect for any loose components, bolts, etc.
6. Verify that the spindle and collet nut threads are clean of debris and are undamaged.
7. Ensure the slots in the collets are free of sawdust and debris.
8. Ensure the dust collection equipment is free of blockages.
9. Check that all electrical connectors are fitted correctly and are not loose or damaged.

Ball Nut Bearing Service (Every 500 Machine-Hours)

The roller ball screws, which are found on each axis of the machine, feature a recirculating bearing assembly (ball-nut bearing) which simply rides along the threaded shaft of the roller ball screws. This transfers the rotation of the stepper motors into linear movement along an axis. Each of these bearing assemblies include a grease fitting used for

lubrication during servicing. You can use any mineral-oil based grease, such as Lucas Oil Extra Duty. Follow the steps below to lubricate the bearing assemblies.

1. Position the axis near the middle of its travel
2. Loosen and remove the bearing assembly mounting screws (4 cap-screws per assembly).
3. Slide the axis away from the bearing assembly.
4. Attach grease gun to the grease fitting.
5. Use gentle pressure to insert grease into the assembly. Be careful to not damage the seals. Note: While applying grease, jog the bearing assembly each direction. This helps the grease to better work into the bearing assembly.
6. Reposition the bearing assembly to the axis.
7. Reinsert the mounting screws, leaving them slightly loose.
8. Jog the axis to the end of the gantry, placing the bearing assembly closest to the fixed end of the axis.
9. Continue to service the next axis or resume normal operation.

Air Cooling Fan (Every 500 Machine-Hours)

The electric box cooling fan is located on the rear of the machine base. Keep the cooling fan free from any blockages that would disrupt the airflow.

The spindle is air cooled. Keep the cooling fan free from any blockages that would disrupt airflow. Be sure to wipe down the area around the fan on the top of the spindle encasement to remove any dust after every use. You can also use a vacuum or air compressor to remove dust from the local area.

13.0 Troubleshooting

13.1 Mechanical & Electric Problems

Trouble	Probable Cause	Remedy
Machine does not power on.	E-stop switch engaged.	Release red E-stop switch.
	No incoming power.	Check power plug connection. Check condition of power cable.
	Faulty power button.	Inspect and replace.
	Circuit breaker tripping.	Do not use GFCI outlet. Power machine directly.
Motor will not start.	Loose or separated connection.	Inspect all connections between motor and control box. Some connections may be hidden.
	Short circuit in wiring or plug.	Inspect wiring or plug for damaged insulation and shorted wires.
	Blown fuse.	Test and install correct fuses.
Machine axis fails to home.	Wiring points disconnected.	Check that connection points are properly seated.
	Loose coupling between motor and ball screw.	Tighten two coupling screws.
	Limit sensor failure.	Place screwdriver head on crosshair of yellow limit switch. Red light should appear and trigger axis limit in UCCNC and green LED in diagnostics screen. If not, replace limit sensor.
	Limit switches damaged, disconnected, or misadjusted.	Inspect that limit sensors and plate are in correct position. If not, correct problem.
Spindle cutting depth inconsistent.	Loose cutter.	Tighten cutter in spindle collet.
	Loose coupling between motor and ball screw.	Tighten two coupling screws.
	Spoil boards not flat.	Check that spoil boards are flat and clean prior to fitting job. Run surfacing bit on MDF.
	Incorrect feeds and speeds.	Check and use proper feed and spindle RPMs for material.
Inconsistent cuts on axis.	Improper feeds and speeds.	Check that you are using correct bit type for material and reference feeds and speeds guide for machine.
	Loose coupling between motor and ball screw.	Tighten two coupling screws.

13.2 Software Errors

Trouble	Probable Cause	Remedy
Error 04	Noise from external electrical source.	Reboot the system. Add extra grounding to your dust collector unit.
UCCNC in demo mode	License not installed.	Cut & paste UCCNC license in C-drive, UCCNC folder.
	Network IP incorrect.	Reference section 9.1 <i>Install and Configure UCCNC Software</i> .
UCCNC disconnects	Faulty PC network card.	Check that your ethernet port on PC is properly working.
	Faulty grounding.	Install extra grounding wires from control box to machine bed.
	Faulty ethernet cable.	Text connection with new cable.
	AXBB board needs reset.	Reset AXBB board by pressing reset button with end of safety pin.

14.0 Replacement Parts

Replacement parts are listed on the following pages. To order parts or reach our service department, call 844-446-9303 Monday through Friday, 8:00 a.m. to 5:00 p.m. CST. Having the Model Number and Serial Number of your machine available when you call will allow us to serve you quickly and accurately.

Non-proprietary parts, such as fasteners, can be found at local hardware stores, or may be ordered from AXIOM.

Some parts are shown for reference only and may not be available individually.

14.1.1 X-Axis Assembly – Exploded View

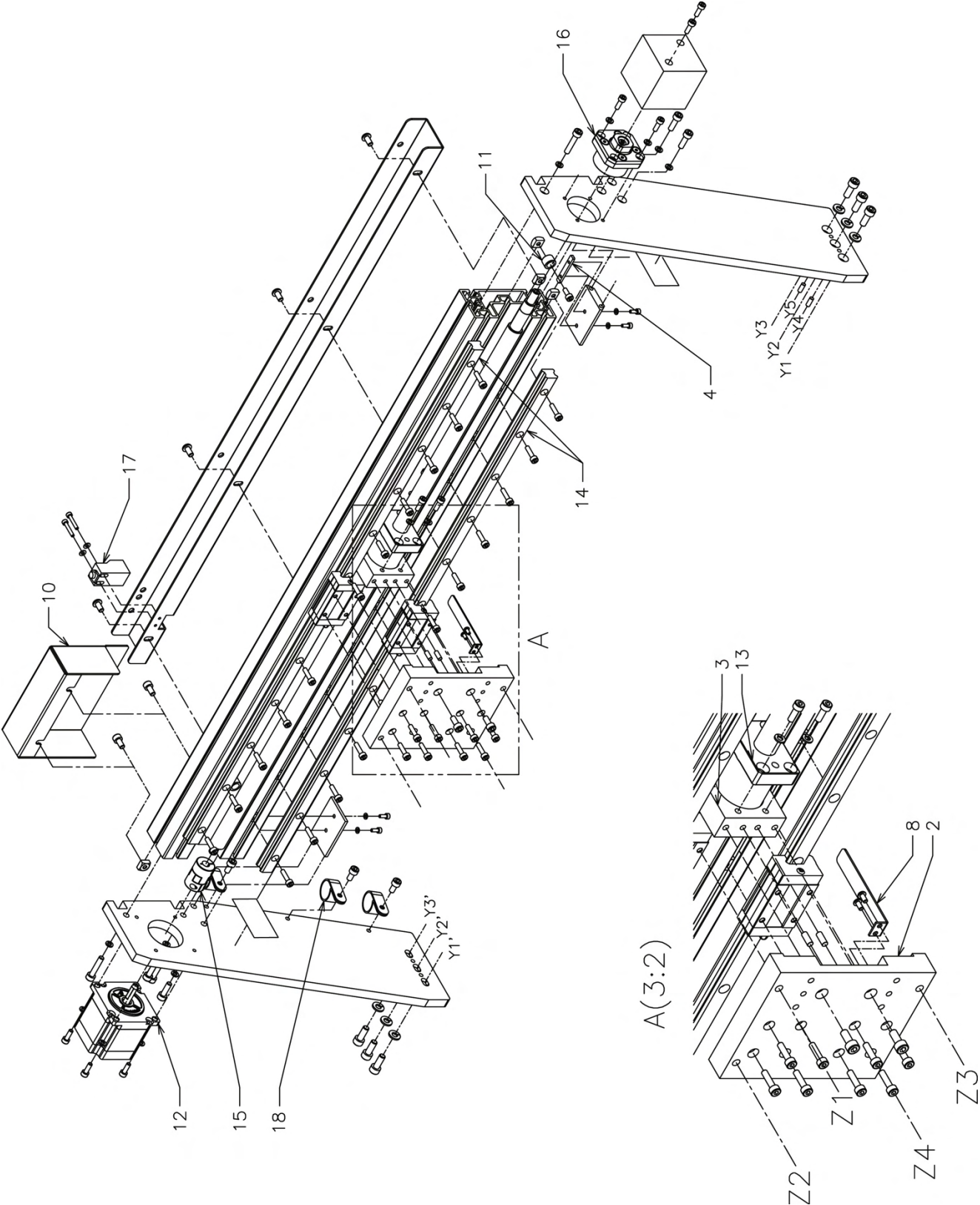

14.1.2 Y-Axis Assembly – Exploded View

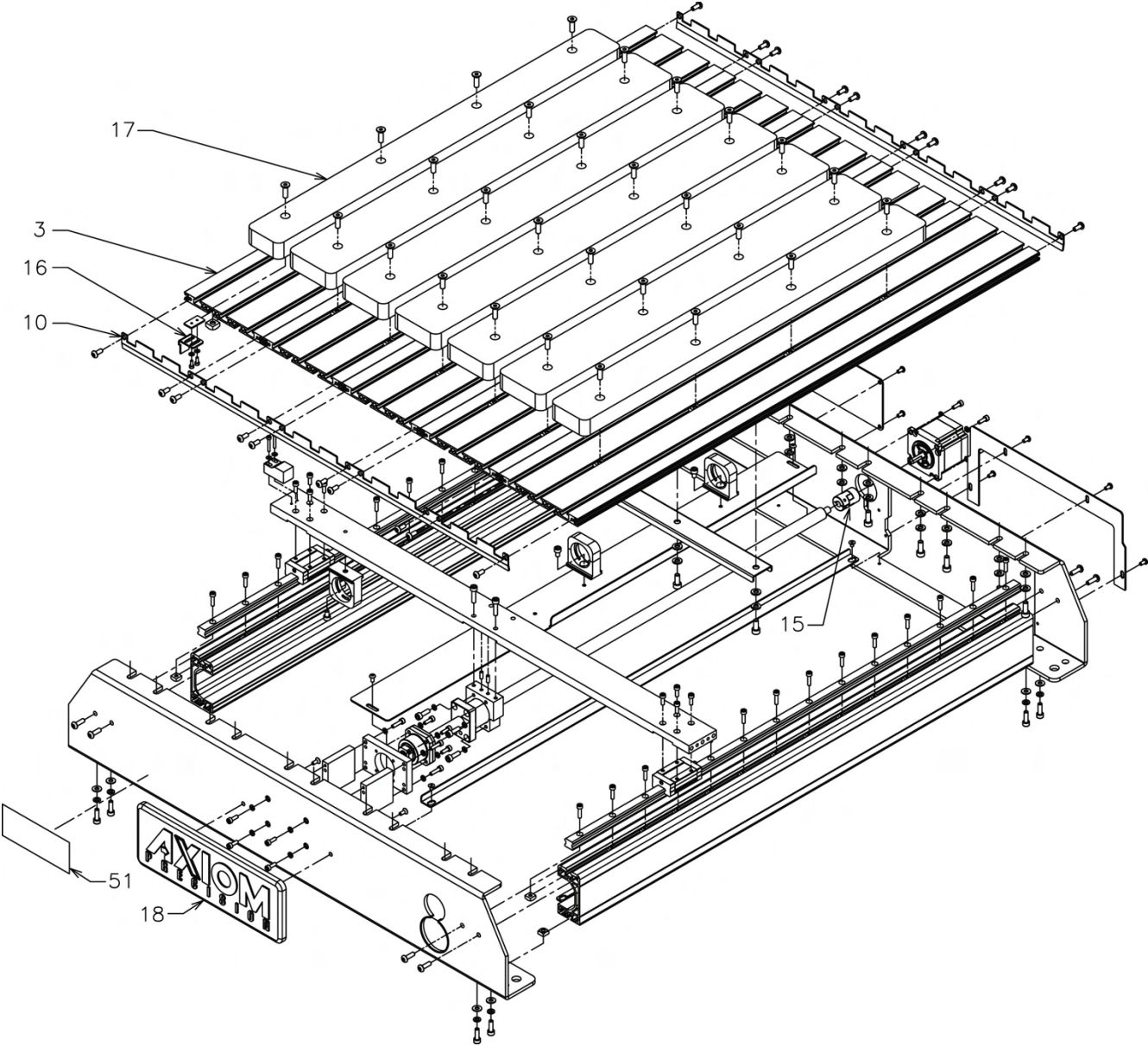

14.1.3 Z-Axis Assembly – Exploded View

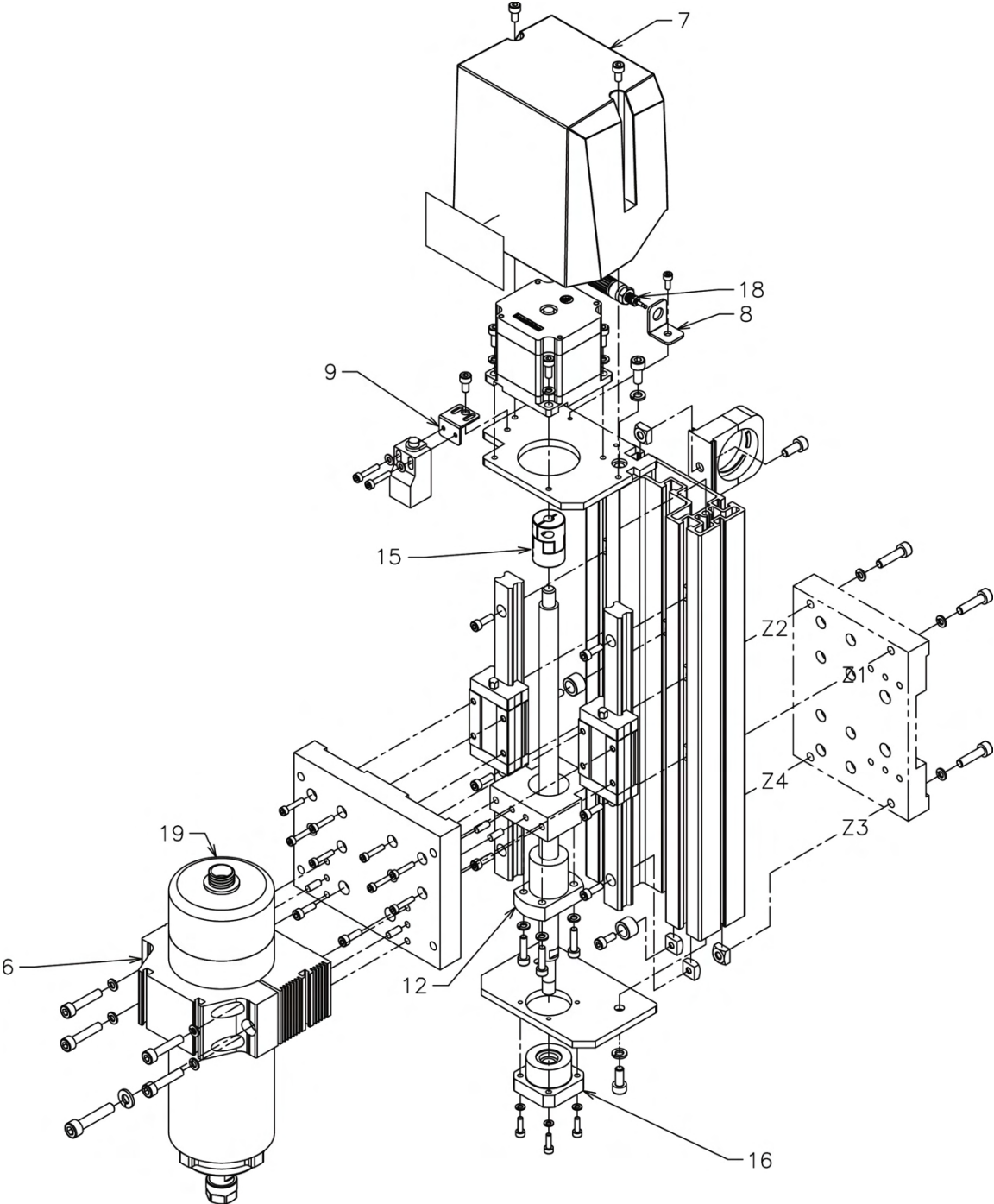

Y-Axis

Index No.	Part No.	Description	Size	Qty
3	AX1-117	ALUM EXTRUSION BEAM		5
10	AX1-118	Y-AXIS L/R COVER		2
15	AX1-113	Coupling		1
16	AX1-119	Sensor Response Plate B		1
17	AX1-120	MDF Board Set: Qty 5, 80mm wide (middle); Qty 2, 65mm wide (sides)		1
18	AX1-121	AXIOM LOGO		1
51	AX1-123	WARNING LABEL		1
	AX1-124	LEVELING PAD SET OF 4X		1

Z-Axis

Index No.	Part No.	Description	Size	Qty
6	AX1-125	Motor Holder		1
7	AX1-126	Z Axis Top Cover		1
8	AX1-127	Binding Post-Black Seat		1
9	AX1-128	Sensor Fixed Plate		1
12	AX1-129	Ball Screw		1
15	AX1-113	Coupling		1
16	AX1-130	Ball Screw Support Unit		1
18	AX1-131	Binding Post-Black		1
19	AX1-132	Spindle		1

Electrical Box

Index No.	Part No.	Description	Size	Qty
4	AX1-133	Inverter		1
5	AX1-134	UCCNC Control Board		1
6	AX1-135	Power Supply	350W/24V	1
7	AX1-136	Power Supply	25W/5V	1
10	AX1-137	Brushless Fan		1
11	AX1-138	Fan Grill (Metall) Generic		1
13	AX1-139	Overload Switch		1
14	AX1-140	Power Filter		1
15	AX1-141	Stepper Motor Controller		3
17	AX1-142	Emergency Stop Switch		1
18	AX1-143	Protective Shell		1
19	AX1-144	Main Power Switch		1
21	AX1-145	Inverter Display Panel		1
23	AX1-146	Relay		2

Available, Not Shown

Part No.	Description	Size	Qty
AX1-147	Accessories Kit (open wrench, chuck, puck, pads, power cord, etc.)		1
AX1-148	Z-Axis Kit Assembly (without spindle)		1
AX1-149	X-Axis Complete Compound Assembly		1
AX9-EHRP13HC12	Touch Off Puck		1
AX9-AMCO424	1/4" Collet, Pre-Installed on Spindle		1
AX9-AMCO420	1/8" Collet, Included in Accessory Package		1

15.0 Electrical Connections

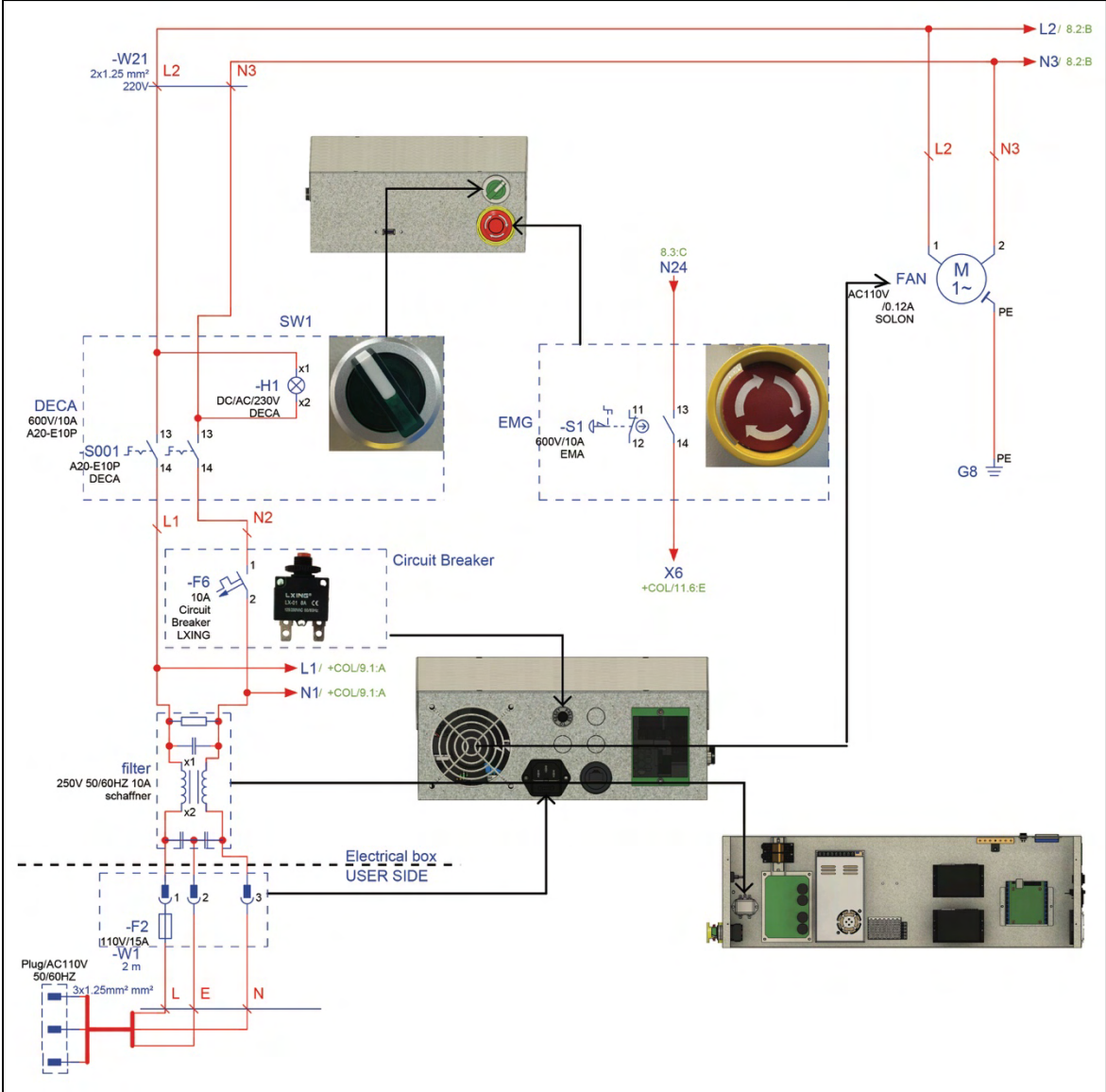

Main Power Box

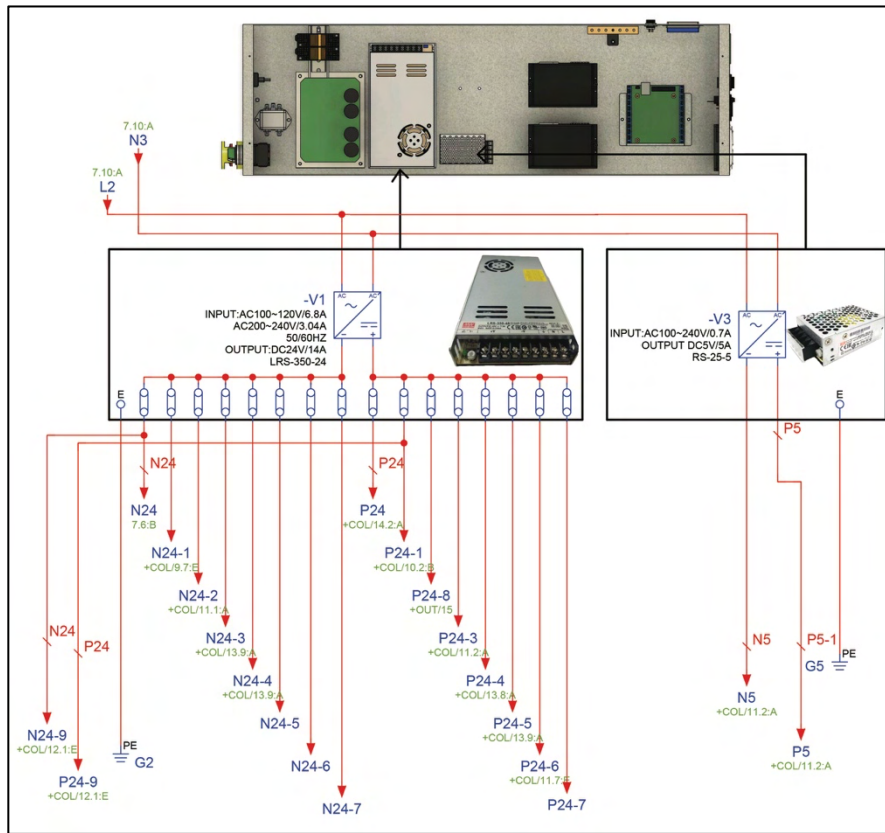

LS1000

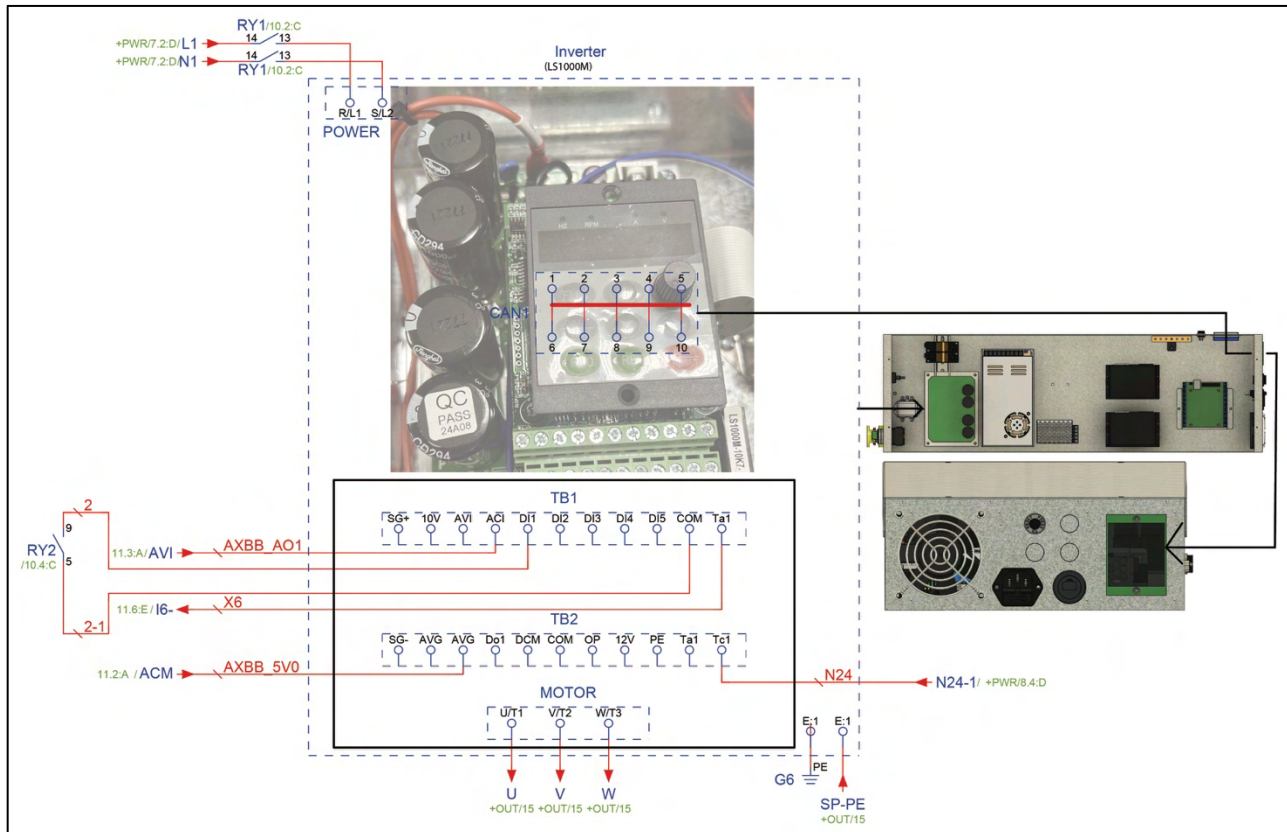

101 Relay

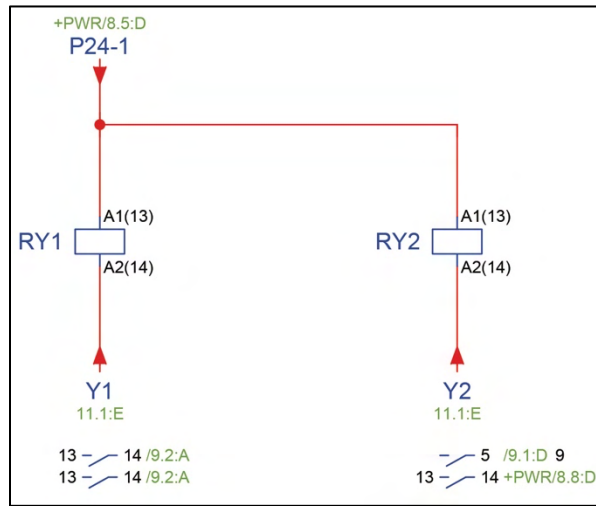

AXBB-E

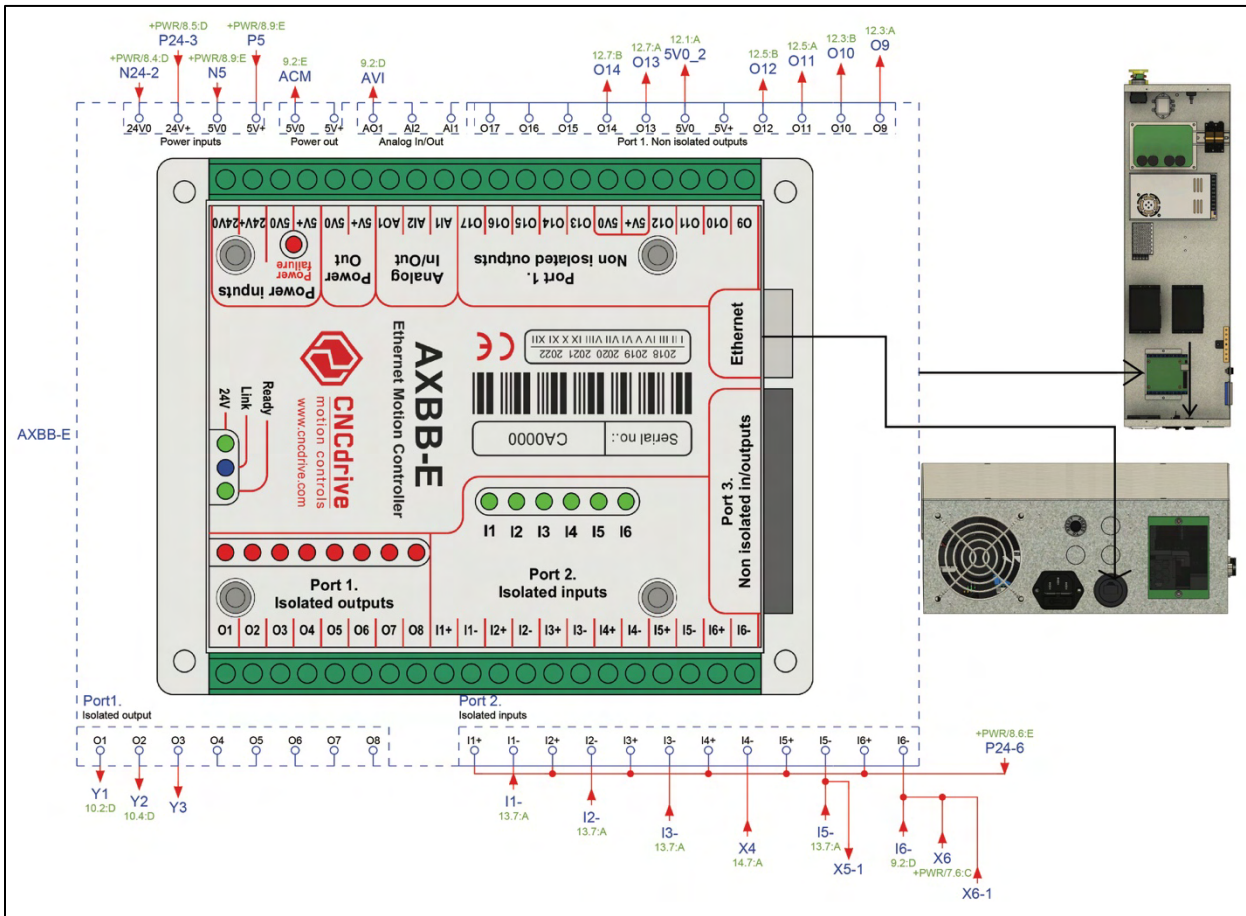

DM542

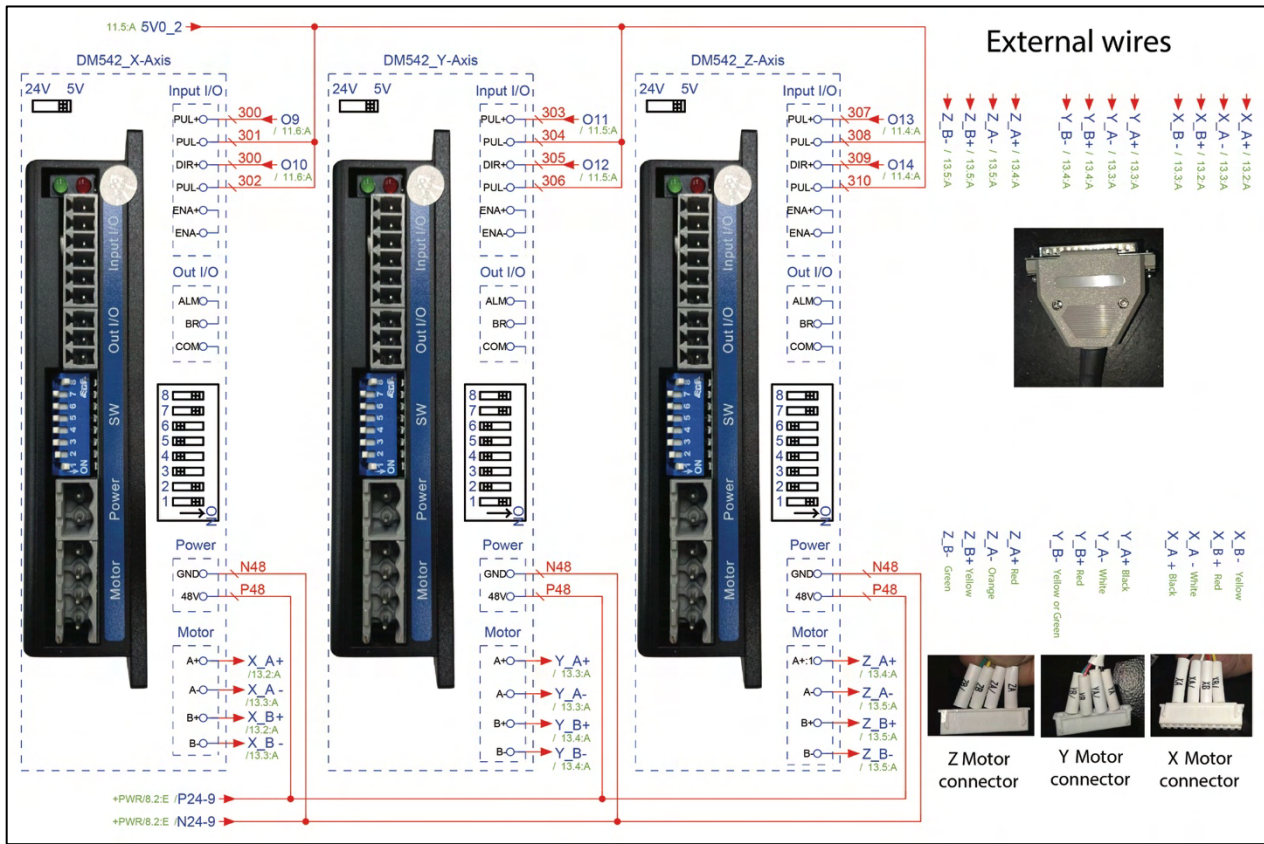

EBRP16-01

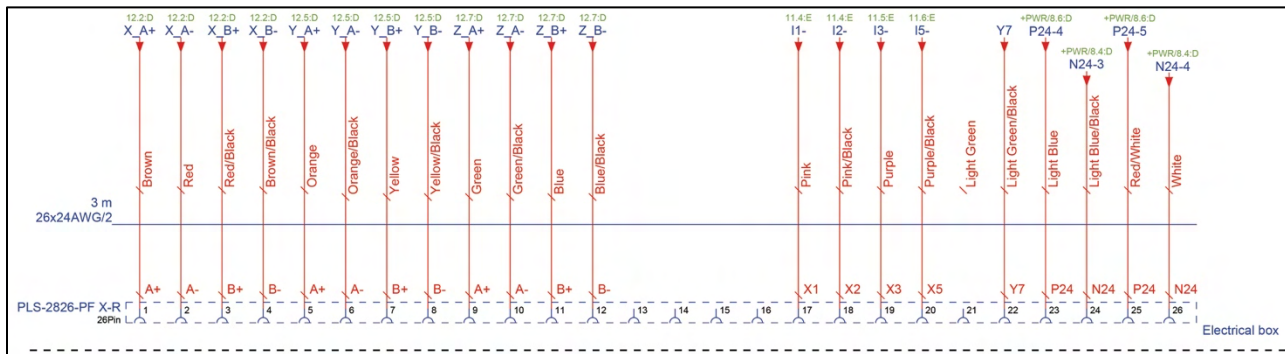

Side Sensor

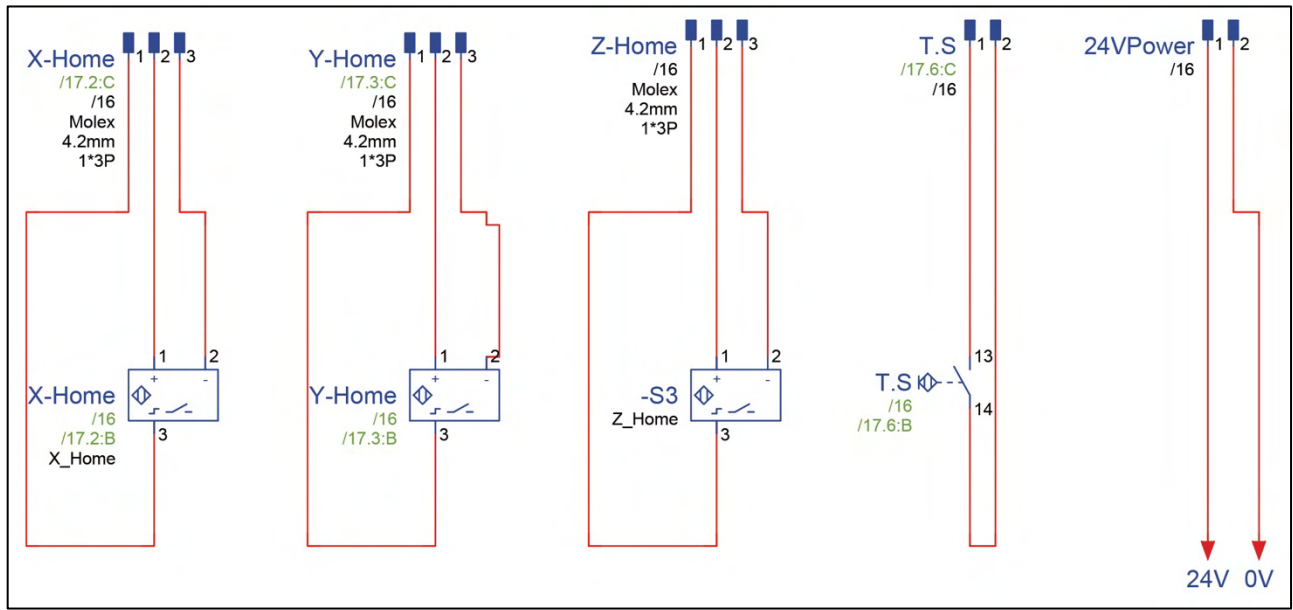

NOTES



427 New Sanford Road
LaVergne, Tennessee 37086
Phone: 844-446-9303
www.axiomprecision.com